



Research
Architecture—Perspective

A New Look at Building Facades as Infrastructure

Doris Sung^{a,b}

^a School of Architecture, University of Southern California, Los Angeles, CA 90089, USA

^b DOSU Studio Architecture, Rolling Hills, CA 90274, USA

ARTICLE INFO

Article history:

Received 21 February 2016

Revised 1 March 2016

Accepted 9 March 2016

Available online 31 March 2016

Keywords:

Building facade infrastructure

Public pedestrian comfort

Building facades for public Health

ABSTRACT

Like the hard surfaces of streets and sidewalks in an urban environment, the vertical and horizontal surface area on the outside of urban buildings contributes to the constant heating of large cities around the world. However, little is done to design this surface to benefit the public sphere. Instead, the facade of a building performs either as a component that focuses only on the quality of comfort for interior occupants, while ignoring effects on the exterior of the building, or as an identifiable aesthetic for the building's owners. This essay proposes the rethinking of the building facade as a steward of outdoor pedestrian welfare, and the conception of public health as an added function of the building envelope—a concept that may fall into the jurisdiction of public works. If the huge total surface area of a city's buildings is thought of as part of the city's infrastructure, then its public contribution may not only make outdoor areas comfortable, clean, and enjoyable, but also help to alleviate the bigger problem of rising temperatures in cities.

© 2016 THE AUTHORS. Published by Elsevier LTD on behalf of Chinese Academy of Engineering and Higher Education Press Limited Company. This is an open access article under the CC BY-NC-ND license (<http://creativecommons.org/licenses/by-nc-nd/4.0/>).

1. Introduction: Not just a pretty face

The fundamental physiology of animals, including humans, operates with only one goal in mind—to sustain itself. The main purpose of the body's liminal surface is to moderate the outside environment in order to ensure the efficient operation of what is on the inside. Trees and plants, on the other hand, more selflessly contribute to the earth's climate. Serving the animal kingdom, these life-giving organisms provide many things for others to survive by means such as photosynthesis (synthesizing carbon dioxide and generating oxygen). This altruistic relationship can inform ways in which the built environment maybe developed in a more public-spirited manner. With so many hard surfaces being built in urban areas, more consideration should be put into the potential of these surfaces to actively contribute to the urban climate. Although some designers are already engineering facades to collect energy, respond to the changing environment, and protect the occupants from intolerable situations, the purpose of most urban building facades is to be a “pretty face” to the public eye. Howev-

er, that same liminal surface can be designed and engineered to do much more, thereby contributing to the common good. Surfaces on the outside of buildings can filter air, clean water, regulate temperature, generate breeze, and contribute to public health. When considered in such a way, the outside of a building may be better categorized as part of a hybridized area of public works, private development, or even public art—or what some may consider to be infrastructure.

2. Background: Self-centric building capsules

The unequivocal warming of the earth's climate is mainly due to an increase in greenhouse gases produced by humans. The crisis caused by burning and depleting our limited supplies of fossil fuels has provoked a critical and wide spread need to generate new sources of renewable energy, as well as viable solutions for zero-energy living. It is sobering to review current statistics that delineate energy consumption in the US; buildings account for roughly 47.6% of all energy usage[†] (Fig. 1), markedly more than

E-mail address: doris@dosu-arch.com

[†] Source ©2013 2030, Inc./Architecture2030. Data Source: US Energy Information Administration (2012). Available from: http://architecture2030.org/buildings_problem_why/.

<http://dx.doi.org/10.1016/J.ENG.2016.01.008>

2095-8099/© 2016 THE AUTHORS. Published by Elsevier LTD on behalf of Chinese Academy of Engineering and Higher Education Press Limited Company. This is an open access article under the CC BY-NC-ND license (<http://creativecommons.org/licenses/by-nc-nd/4.0/>).

the usages for industry and transportation. From large-scale infrastructural projects to small-scale houses, heating and cooling consume gargantuan amounts of resources; a situation made clear by the fact that energy usage comprises the single largest expense for commercial office buildings. In many urban areas around the world where there are large areas of exposed urban surfaces, this crisis is exacerbated by the well-documented “heat-island effect.” The city’s sidewalks, streets, and hard surfaces emit the heat it has absorbed during the day, preventing the city from cooling down at night. The compounding rising temperatures in cities cause residents to turn up the air conditioning, which in turn generates more heat that is sent into the atmosphere and contributes to the vicious cycle of rising urban temperatures. In addition to the need to diminish the use of heating, ventilating, and air-conditioning (HVAC) systems and bring down energy consumption in buildings, urban pedestrian areas are becoming unbearable and must somehow be included in the energy equation.

Prior to the 1900s, buildings were constructed with thick walls and small windows, providing an undeniable separation between interior and exterior. Humanity’s natural inclination to commune with nature was superseded by the benefits provided by dense load-bearing walls, which provided natural insulation. The interiors were cool during the summer and warm in the winter with very little heat loss through the small openings. However, with the introduction of plate glass and rolled steel in the 1930s, architects began to design houses with floor-to-ceiling glass exterior walls, introducing the idea that “form follows function”—that is, exposing all building components and spatial functions on the building’s facade, in an effort to seek honesty and transparency in design. Along with the undeniable visual, physical, and aesthetic benefits came some less-than-salutary side effects: tremendous heat gain from the penetrating sun, unstable interior temperatures from a lack of insulation, and an irreversible reliance on artificial cooling/heating. As commercial buildings grew taller with the evolution of structural steel and elevator technologies, HVAC systems likewise became more complex, requiring increasing amounts of energy and dispersing tremendous amounts of heat into the atmosphere; and building envelopes were designed to hermetically seal and insulate the interior cavity for excessive levels of comfort. For safety and HVAC efficiency, windows in new commercial structures were made inoperable, making these buildings uninhabitable during power outages and exposing our absurd reliance on energy-consuming mechanical systems and capsule-like building envelopes.

Today, at this critical juncture, the building envelope must be

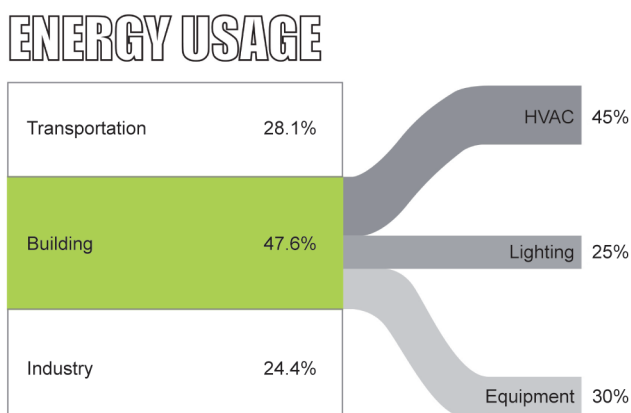

Fig. 1. Because 47.6% of all energy is used by buildings, any reduction or contribution back would make a large dent in overall energy savings. (Image courtesy of DOSU Studio Architecture.)

reconsidered. Architects must conceptualize the building skin as a true mediator between the interior and exterior environments: first, as a potentially responsive system for the purposes of zero-energy human occupation; and second, as a responsible and active participant in its adjacent spaces. Instead of metaphorically turning its back on the urban environment, the outside surface of a building can improve pedestrian thermal comfort, acoustics, reflectivity, air quality, and wind-driven rain to make outdoor areas more comfortable and useful. In addition, because our environment is changing hourly, daily, seasonally, and annually, we need to design building envelopes that are dynamic, responsive, and intelligent.

Rather than simply mimic biologic skins, which selfishly perform as liminal surfaces for the biologic mass within, designers can use technology to progress beyond this concept and make multi-functioning building skins, in which there is virtually no “outside surface,” and in which the outside surface can function completely differently than the inside (i.e., with form not following function). Because the surface area of building facades covers huge amounts of square footage—sometimes more than those of streets and sidewalks—building facades are both the culprits and the potential saviors of urban rut. In other words, even though they have contributed to the problem of the heat-island effect in the past, building facades can be repurposed to offset these and other problems in the future. Given the newer technology now available and a greater interest in urban climate, buildings’ outer surfaces can filter pollution, promote air circulation, and generate clean water—at most, contributing to the common good of society at large, and at least, making outdoor pedestrian spaces healthier, more comfortable, and markedly more useful. Because the outer surface of a building literally touches the urban environment along its entire perimeter, that same surface has a responsibility to take on a more active role in that arena, in addition to its already self-centered purpose of encapsulating the building.

3. Split personality: Outside surface belongs to the city, inside to the building

High-rise facades have not witnessed a major innovation since Ludwig Mies van der Rohe unleashed the glass-box curtain-wall over 80 years ago. The time is ripe to advance major change, reduce the use of energy, and assume a major role in controlling the urban climate by making the outside surfaces of buildings contribute to urban welfare, public health, and pedestrian comfort. The two sides of a building facade should each perform for the side it faces—one for the inside and the other for the outside. Once this concept takes hold, the perception of what architecture should be or do will change dramatically, and we might witness something like the explosive growth in popularity of the cellular telephone. Telephone technology was stagnant for 100 years before cellular telephones emerged. In a short amount of time, fueled by the invention of digital transmission, the use of mobile devices grew astonishingly fast, leading to a boom in the development of smart devices, positioning systems, and digital applications. It is hard to remember what life was like before cell phones. The same explosive growth can happen with respect to building envelopes.

Building envelope and facade design, currently a hot topic in Europe, will inevitably be influenced by the use of smart and low-energy systems. Thomas Auer of Transsolar KlimaEngineering, the climate engineer for the Manitoba Hydro Headquarters project, has extensive experience and interest in the design of the building envelope. He believes that, on a material level and in addition to self-ventilation, the skin of a building can perform much like a dehumidifier, drawing moisture out the air and even gener-

ating water for various uses. Simple material combinations such as silica coatings can enhance the behavior of some materials to have a local effect on an integrated intelligent facade system[†]. Similarly, a product by Alcoa Architectural Products called “Eco-Clean” is almost smog-eating. With a coating of titanium dioxide on an aluminum surface, the hydrophilic surfaces allow water to cascade off rather than bead up, self-washing the surface of particulate matter and other types of smog. Free radicals released by the interaction of titanium dioxide with sunlight, water, and oxygen attack NO_x molecules on or near the surface, converting them into nitrates[‡]. The president of the company, Craig Belnap, says, “If a fraction of [North American and European building] surfaces use the EcoClean product, it would be the equivalent of planting several million trees.”^{††} The impact on air quality would be tremendous, both locally and globally.

Projects such as the Urban Urchin by this author and Russell Fortmeyer of ARUP, or TW/RL by this author with Simon Schleicher at University of California, Berkeley, and Julian Leinhard of structure (Figs. 2–5), use low-tech strategies to provide shade and promote breeze in adjacent areas while filtering air through the structure. In both cases, hot air collected in solar chimneys by thermo-bimetal solar collectors rises to escape, letting in cooler air below. No artificial energy is used in either case. Principles from these studies can contribute to the development of building facades in which the surface forms and promotes specific types of fluid motion of the air and simultaneously attracts pollution particulates (Fig. 6). Research in this area is already promising. Breathe Brick, a research project by Carmen Trudell with a group of students from California Polytechnic State University, San Luis Obispo^{‡‡}, found inspiration in the vortex systems of certain vacuum cleaners. This project involves the use of mini-cyclones inside the exterior wall cavity to remove particulates from the air (Figs. 7, 8). Although this proposal is to make a system that filters outdoor air for indoor use, this simple technology can also be applied to filter outdoor air for outdoor use.

With these types of active-passive intent, buildings that typically only controlled the interior comfort of its occupants can now play an important, active, and altruistic role in controlling the exterior comfort of the urban landscape. The real impact of this type of thinking will ripple through the entire design and construction industry and into greater public spheres. Facades



Fig. 2. To offset the removal of large shade trees in the urban area of Holon, Israel, this unbuilt project, titled Urban Urchin, promoted outdoor living spaces by cooling the pedestrian area below. (Image courtesy of DOSU Studio Architecture.)

will look and perform complete differently, and this shift will inevitably influence the way we design, construct, and occupy space—both indoors and outdoors.

4. Urban surfaces on buildings: A new paradigm for building facades

Historically, the prime and governing semantic message of a building has been indicated by the treatment of the outer surface of the building envelope, or its facade, and has alternated between exposing the important functions of the wall and con-

Cooling sequence

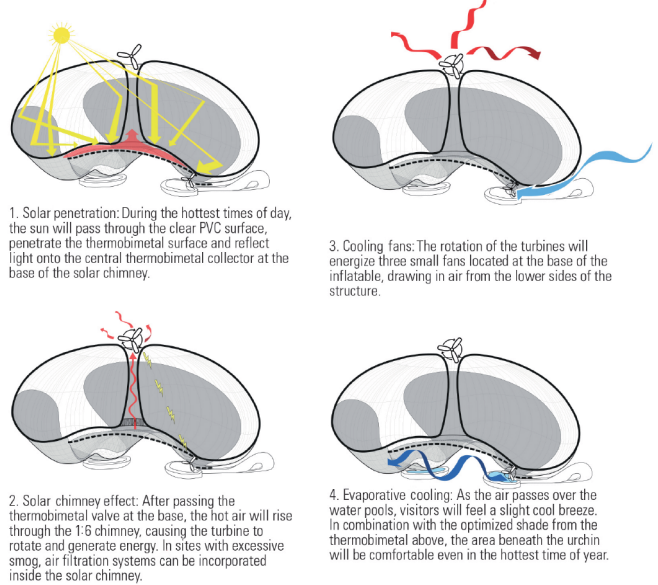

Fig. 3. Collecting solar energy and heat, breezes are generated by a combination of solar chimneys and fans. With air movement, filtration can also be included. (Image courtesy of DOSU Studio Architecture.)



Fig. 4. For the city of Chicago, a similar smaller-scale kiosk project provides shade and breeze during hot summer months. (Image courtesy of DOSU Studio Architecture.)

[†] Thomas Auer’s lecture in the USC School of Architecture Workshop: Top Fuel 2012: Funnels, 2013 Mar 19–26.

[‡] Information obtained from http://alcoa.com/aap/north_america/pdf/ecoclean/EcoClean_Newsletter1.pdf.

^{††} Woody T. Alcoa’s self-cleaning, smog-eating buildings. Tech, Forbes. 2011 May 9.

^{‡‡} Courtney Humphries, “Citation: Breathe Brick,” 2015 R+D Awards, Architect Magazine, 2015 Aug 7.

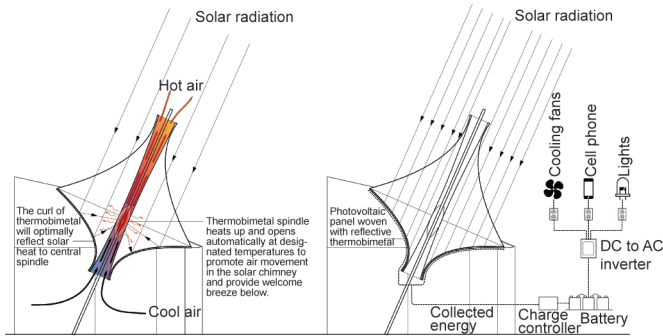

Fig. 5. A combination of solar collection and solar chimneys make air movement possible on a very low-tech system. The umbrella is moved to appropriate angles by the occupants of the kiosk who are seeking shade. (Image courtesy of DOSU Studio Architecture.)

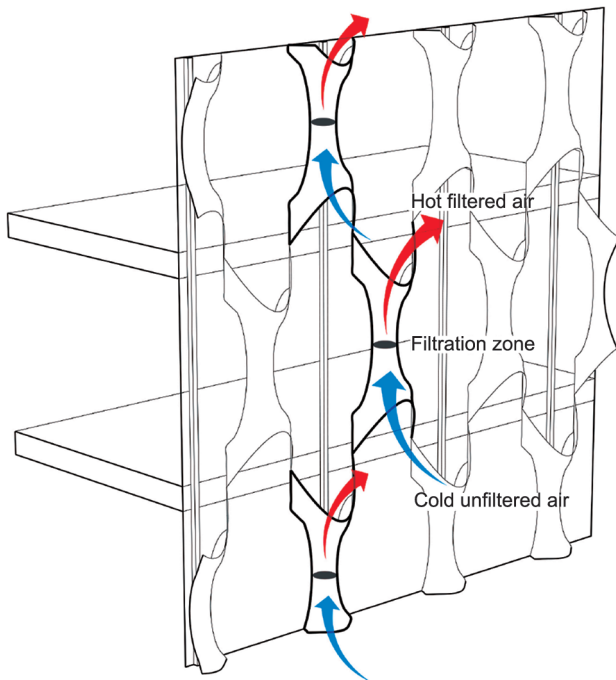

Fig. 6. As a single unit, the previous two projects cannot make a significant dent in cooling the city or filtering airborne particulate matter. However, when considered for larger surface areas such as building facades, the results can be much more effective. (Image courtesy of DOSU Studio Architecture.)

veying hierarchies of values and claims of power. Back when early humans lived in caves, dwellings had no outer surfaces—only an interior cavity. The eventual stacking of stones and other materials produced a new building element (walls), making it possible for humans to live in the open while being protected from the elements. These early stone walls expressed their load-bearing function. Later, walls were made smooth with the use of mud, wood, and other materials and became canvases for imagery, sculpting, and expression. The two- and three-dimensional ornamentation on these surfaces indicated the use, history, or importance of the structures behind them (Fig. 9). The addition of building services such as heating/cooling and plumbing contributed to the historic development of the building's envelope; a development that can be seen in the integration of chimneys (Fig. 10) and in the location of radiators beneath windows. In the 20th century, interest in expressing honesty in the facade as either an extreme technological

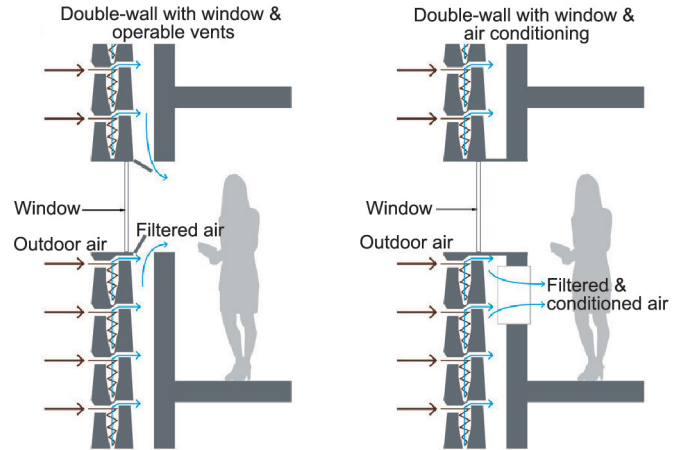

Fig. 7. Breathe Brick filters air from the outside for use on the inside. (Available from: http://www.architectmagazine.com/awards/r-d-awards/citation-breathe-brick_o.)

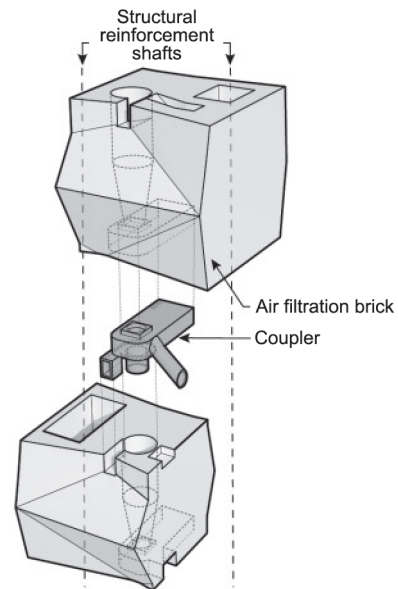

Fig. 8. Like a vacuum, mini-cyclones inside the wall remove particulates from the air. (Available from: http://www.architectmagazine.com/awards/r-d-awards/citation-breathe-brick_o.)

envelope (Fig. 11) or a materially invisible surface (Fig. 12) also became culturally popular. This position was then countered by a return to semantic messaging in the dematerialization of building envelopes by the intense use of lights, electronics, billboards, imagery, and text (Fig. 13), however, such extravagance is unsustainable and marginally irresponsible. The obvious question is: What comes next in the development of the building's envelope?

Environmentally responsive facade systems have been gaining popularity in current trends of facade design. Jean Nouvel first proposed this type of surface in 1987 at Musée de L'Institut du Monde Arabe (Figs. 14, 15), but the idea did not adhere on a cultural level and was therefore abandoned technologically. Since then, times have changed and newer "smart" materials and assemblies are being embraced. Building facades can automatically shade, cool, and ventilate the building interior. In some cases, these processes can be done without the use of energy or



Fig. 9. Carvings on the facade of Angkor Wat were cultural narratives and had little to do with the performative characteristics of the walls or the structure it was on. (Source: Wikimedia Commons.)



Fig. 12. The Farnsworth House by Ludwig Mies van der Rohe was built in 1951. An icon of the modern movement, it embodied the famous mantra of “form follows function.” (Available from: [http://grshop.com/blog/tag/barcelona-chair/page/2/.](http://grshop.com/blog/tag/barcelona-chair/page/2/))



Fig. 10. Mechanical elements such as heating (chimneys) and other functional elements began to define the aesthetics of the facade in the Vicar's Close residential neighborhood in Wells, England in the mid-1300s. (Available from: <http://gotterdammerung.org/photo/travel/england/wells/071121-155330%20Wells%20Cathedral%20Towers%20over%20Vicar's%20Close.html>.)



Fig. 13. Many cities around the world have centers that are predominantly media screens with advertisements, propaganda, and information. These types of facades require a considerable amount of energy and emit unnecessary heat during the time of day that should be reserved for cooling the city. (Available from: [http://lssmedia.com/news/a-preview-of-cherry-blossoms-in-times-square/.](http://lssmedia.com/news/a-preview-of-cherry-blossoms-in-times-square/))



Fig. 11. The Pompidou Center by Renzo Piano and Richard Rogers was built in 1977. All of the structural and mechanical systems were exposed on the outside of the building and became part of the facade aesthetics. (Image courtesy of DOSU Studio Architecture.)

controls[†]. However, assuming that this type of construction becomes established, the next consideration is a building's contribution to its immediate external environment and then to the areas beyond, such as the greater city. A number of densely populated climates are not conducive to outdoor living during certain



Fig. 14. The facade of Musée de L'Institut du Monde Arabe in Paris was an attempt to make a facade respond to the moving sun. (Image courtesy of DOSU Studio Architecture.)

[†] Doris Sung's work on thermo-bimetallic architecture components has produced window systems, structural walls, and even self-assembly systems.

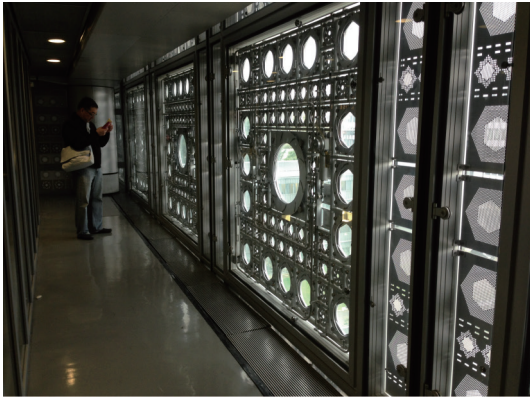

Fig. 15. Because the sensors were too sensitive, much of the moving mechanism is no longer in use. (Image courtesy of DOSU Studio Architecture.)

times of the year (i.e., areas along the equator or near the poles) and there are health concerns related to the quality of outdoor air, water, and lifestyles. Clearly, an attitude that does not bias the interior of a building over the exterior is in order.

Interest in reducing energy usage, innovations in fabrication technology, and recessions in the economy set the stage for a renewed interest in the development of the wall section. To advance, architects must establish a new understanding of the con-

cept of a “wall section,” in which the building skin performs on both technical and programmatic platforms—on both surfaces of the building’s outer envelope. Changes in the building envelope will affect the entire building design and will certainly influence the manner in which floor plans are organized, while a building’s interior will come to affect the street use on the outside of the wall. Such changes will also challenge the semiotic value of the facade surface and question our former mantra of “form follows function.” Will the middle portion of a building’s wall section be a marriage of two different walls—one for the outside and one for the inside—or will it be a clash of completely separate meaning? Will the “form follows function” mantra apply to both sides of the exterior walls or will it eventually negate itself? Are we in fact dismantling Mies van der Rohe’s motto of “less is more” and replacing it with the new mantra of “more is more?”

Adding a new function to the outside surface of a building’s facade’s aesthetics is clearly a complex undertaking. However, these complexities are not as far-reaching as one may think and will require careful consideration in the years to come. The biggest challenge will be economic. Government involvement may be required to make change happen, but it is easy to imagine that “although academia has provided models for industry to test, we find few regulatory or approving agencies willing to take up the cause in any official way.”[†] Despite these hurdles, understanding the value of building facades as a new type of infrastructure is already a step in a new direction.

[†] Fortmeyer R. When good climates go bad. *AR Technology*, Australian Design Review, p. 54.