

Key Technologies and Prospects of All-Climate New Energy Vehicles

Wang Wenwei, Sun Fengchun

National Engineering Laboratory for Electric Vehicles, Beijing Institute of Technology, Beijing 100081, China

Abstract: An all-climate new energy vehicle can adapt to various climatic conditions including high temperature, high humidity, and extreme cold. Currently, mature heat insulation and protective technologies have been developed to cope with high-temperature and high-humidity environments. However, at temperatures below $-30\text{ }^{\circ}\text{C}$, new energy vehicles are incapable of starting and hard to charge; furthermore, their driving range drops markedly. These problems restrict the all-climate application of new energy vehicles. In this paper, the power battery self-heating, integrated heat pump air conditioning, and new whole-vehicle thermal insulation technologies are investigated. Integrated vehicle development and tests in extremely cold environments have been conducted. Technology development trends for all-climate new energy vehicles are also analyzed. The research achievements described in this paper will be applied to the Beijing 2022 Olympic Winter Games, thus promoting the all-climate application of new energy vehicles in China and throughout the world.

Keywords: all-climate new energy vehicle; battery self-heating; heat pump air conditioning; thermal insulation

1 Introduction

In recent years, the new energy automobile industry in China has developed rapidly, with the technical level and the industrial supply chain greatly improving. The corresponding development achievements have attracted worldwide attention [1]. However, as the new energy vehicle market develops, the meteorological climate has great influence on new energy vehicle performance. Compared with the impacts of high-temperature and high-humidity environments on mature technologies such as battery cooling and electrical protection [2,3], the impact of extremely cold environments on new energy vehicles comprehensive performance (including driving range, start-up time, air conditioning performance, safety and reliability, etc.) is severe. It is an internationally recognized technical problem and a “forbidden zone” for the operation of new energy vehicles.

According to data from the national monitoring and management platform for new energy vehicles, new energy vehicle application clusters in China are mainly located in the central and eastern regions, including Beijing–Tianjin–Hebei, Jiangsu–Zhejiang–Shanghai, and the Zhujiang Delta. However, the northwest and northeast of China have almost been “vacuum zones” for the application of new energy vehicles. The adaptability of new energy vehicles in low-temperature environments, especially the problem of “mileage anxiety” under low-temperature conditions, has become a constraint for large-scale promotion of electric vehicles, adding to an already substantial list of constraints: local economic development level, population concentration, policies, and other factors [4].

Recently, the American Automobile Association conducted a mileage test on a number of new energy vehicles from Tesla, BMW Group, General Motors, Volkswagen, and Nissan. The research showed that with the air

Received date: May 7, 2019; **Revised date:** May 28, 2019

Corresponding author: Sun Fengchun, Professor from the National Engineering Laboratory for Electric Vehicles, Beijing Institute of Technology. Major research field is vehicle engineering. E-mail: sunfch@bit.edu.cn

Funding program: CAE Advisory Project “Strategic Research on Development of Green and Low-carbon Industries” (2018-ZD-12)

Chinese version: Strategic Study of CAE 2019, 21 (3): 047–055

Cited item: Wang Wenwei et al. Key Technologies and Prospects of All-Climate New Energy Vehicles. *Strategic Study of CAE*, <https://doi.org/10.15302/J-SSCAE-2019.03.020>

conditioning systems on, the driving range of new energy vehicles declines by 17% below 35 °C, and by 41% under -7 °C, compared with the driving range at 24 °C [5].

This and other problems, such as the inability to start, difficulty in charging, and potential safety hazards in extremely cold environments, are major obstacles to the large-scale application of new energy vehicles. Therefore, based on the major problems that restrict new energy vehicle use in low-temperature environments, we propose rapid self-heating technology; high-efficiency, low-temperature, enthalpy-enhanced air conditioning, and thermal insulation. These technologies solve the corresponding problems for new energy vehicles in environments of extreme cold.

2 Technology programs for all-climate new energy vehicles

2.1 Lithium-ion power battery self-heating technology

Lithium-ion battery systems exhibit significant performance degradations at low temperatures. First, battery capacity is significantly attenuated, resulting in a significant decline in the mileage and dynamic performance of the vehicle. Second, vehicle start-up time is extended, with the vehicle unable to start at -30 °C without external heating. Third, batteries are difficult to charge in low-temperature environments. The traditional method of preheating and then charging has the disadvantages of high-energy consumption, long charging time, high cost, and complicated structure. These factors affect the service life of the battery, and may even cause a safety hazard. The all-climate battery based on the third-pole-nickel-foil activation terminal self-heating technology proposed by Wang et al. has solved the above problems well [6].

2.1.1 All-climate battery self-heating principle

The principle of self-heating of the all-climate battery is shown in Fig. 1. A nickel foil of thickness 50μm is implanted between the electrodes to serve as a self-heating source. When the battery is at a lower temperature, the system controls the switch between the positive electrode and the activation terminal to be closed. The inside of the battery generates a controlled internal artificial short circuit, so that the electron is forced to form a closed loop inside the battery through the nickel foil. As the current passes, a thermal effect is generated on the nickel foil, so that the battery is internally self-heated, and the battery temperature begins to rise. When the battery temperature exceeds 0 °C, the electrochemical reaction inside the battery is activated. The electrochemical reaction provides a more reliable and high-power heating source for the battery, while at the same time performing normal charging and discharging behavior. The switch is then disconnected, and the battery automatically stops self-heating and is put into normal use.

Battery pulse power was measured in terms of Hybrid Pulse Capability (HPPC). For batteries with 50% SOC (state of charge) and 80% SOC, the discharge power at -30 °C was respectively increased to 1061 W/kg and 1600 W/kg. This power level is 5 to 6 times higher than that of ordinary batteries at the same temperature.

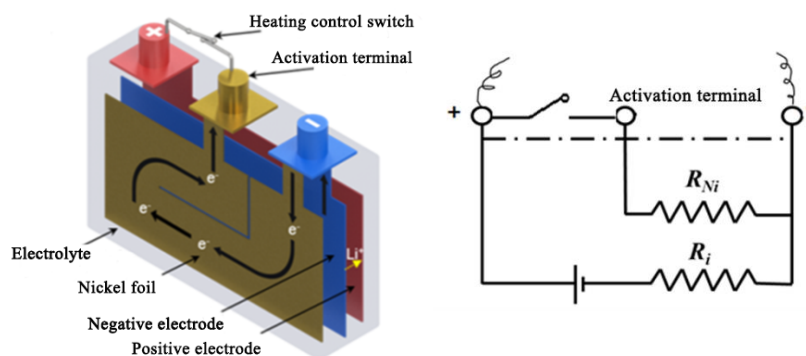

Fig. 1. Schematic diagram of self-heating all-climate battery [6].

The self-heating performance and energy consumption results of the single battery are shown in Fig. 2. The battery can be heated from -30 °C to 0 °C in 30 s, with battery energy consumption remaining below 5% of total battery capacity. Compared with the traditional external heating method, this self-heating technology has the advantages of rapid temperature rise, low-energy consumption, and uniform heating. This technique can thus solve the “bottleneck” problem for battery use in environments of extreme cold.

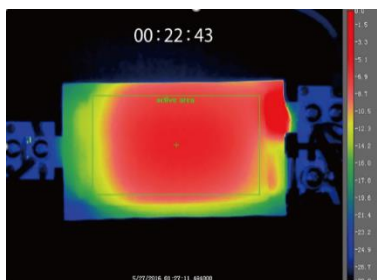

Fig. 2. Experimental result of the single battery heated from $-30\text{ }^{\circ}\text{C}$ to $0\text{ }^{\circ}\text{C}$.

2.1.2 Key technology for single battery

In order for the all-weather battery to achieve industrial production, the Beijing Institute of Technology and MGL have been given responsibility for the all-weather battery and the key technical problems in battery design and production. These institutions have researched and systematically selected the thermal field and geometric parameters of the self-heating technology scheme.

To meet the requirements of industrialized production and save development time, the design of the all-weather battery structure adopts configuration of the activation terminal and the electrode opposite shown in Fig. 3. This kind of design gives the terminal sufficient cross-sectional area to meet the needs of high current output. At the same time, in order to ensure the reliability of the battery package and facilitate packaging with an aluminum plastic film casing, the activation terminal is connected with the same copper-plated nickel electrode as the battery electrodes, and the aluminum plastic film is heat-sealed after the connection is completed.

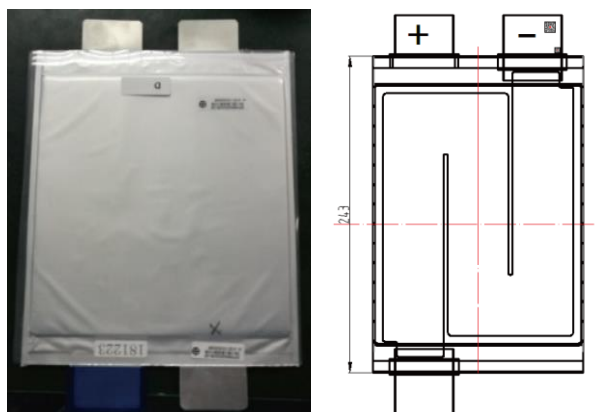

Fig. 3. All-weather battery.

The design of the heating terminal is the key technology of the all-weather battery. In addition to the requirements of heat generation and uniform heating, the heating terminal needs to maintain good insulation from the outside. The scheme requires designing an insulating isolation membrane on the outer surface of the metal heating sheet to ensure that the heating sheet does not come into electrical contact with the outside, and that the metal body of the heating sheet is not in contact with the electrolyte.

Through the analysis of and experiments on the electrical and thermal properties of the heating terminal, the Beijing Institute of Technology and MGL have adopted the outer covering film solution for the all-weather battery shown in Fig. 4. In order to maintain cell capacity and reduce cell thickness, the parameters of the heating film after optimization are based on the principle of higher energy density cell design (Table 1). The resistance of the heating film after optimization is $8\text{ m}\Omega$. The small line width and narrow S-shaped gap can provide more uniform heat production.

The experimental results show that the self-heating of the all-weather battery from $-40\text{ }^{\circ}\text{C}$ to $0\text{ }^{\circ}\text{C}$ took 45 s, with power consumption not exceeding 5% of battery capacity, and maximum temperature deviation between internal and external of the battery less than $5\text{ }^{\circ}\text{C}$. Reliability verification of packaging, pressure resistance, and insulation, showed that the heating film, including ceramic separator and thermal composite technology, can electrically isolate the electrolyte, improving the safety and reliability performance of the all-weather self-heating battery. At present, a 68 Ah high-energy battery has been developed. The basic performance of the battery is as

follows: the specific energy density is 230 Wh/kg, the DC internal resistance is less than 1.2 m Ω under 50% SOC, and the power density is greater than 1500 W/kg. The charging capacity is maintained above 90% after 2 000 charges, in the normal temperature cycle. The single battery has passed safety tests including external short circuit, acupuncture, extrusion, over-charge, and over-discharge.

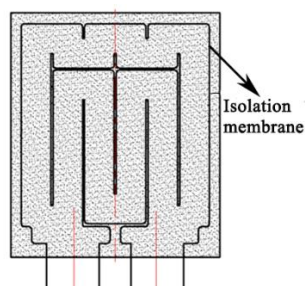

Fig. 4. Heating film.

Table 1. Battery parameters after optimization.

| Parameter | 35 Ah battery |
|---------------------------------------|---------------|
| Energy Density (Wh·kg ⁻¹) | 225 |
| Battery thickness (mm) | 5.4 |
| Layers | 18/20 |
| Battery weight (g) | 690 |

2.1.3 Key technology for battery system

The all-climate battery system as shown in Fig. 5 consists of an insulated sealed enclosure, a battery management system, and a thermal management system. A complete battery management strategy is critical to battery consistency, safety, and durability.



Fig. 5. All-climate battery prototype.

The all-climate battery management system includes a system self-heating control circuit and control strategy (Fig. 6). A prediction model for battery internal temperature allows the system to monitor the thermal response of the battery, and thus thermal runaway behavior is predicted ahead of time. The thermal-electrical coupling management system is improved. A comprehensive physical model of the full-climate power battery is shown in Fig. 7. A comprehensive physical model of the electrochemical mechanism model, a fractional impedance model, and an N-order RC (N-RC) equivalent circuit model are proposed. Through optimization of the battery model and identification of on-line parameters, the battery model uses archiving and real-time operation data to realize multi-scale joint estimation of dynamic capacity and SOC. This advance guarantees the service life and performance of the battery.

The low-temperature self-heating technology of the all-climate battery thermal management system adopts a one-button heating control mode (Fig. 8). By analyzing the vehicle starting condition, emergency situation and

vehicle charging state, the logic design ensures that the battery can obtain effective heating under various working conditions, and at the same time improves the importance of driver decision-making and human-computer interaction.

The system fully considers environmental adaptability, since the vehicle may encounter unusual driving conditions like flooded roads. The continuous protection capability testing process is shown in Fig. 9. After strict system design and testing, the battery system achieves IP68 protection level and can meet the requirements of all-climate and road conditions.

2.1.4 Low-temperature, whole-vehicle test

During the winter of 2018/2019, this study conducted several tests of a 12 m electric bus, a 7 m electric light bus, and an electric passenger vehicle in the extremely cold of Hailar in Inner Mongolia. The vehicles remained in $-30\text{ }^{\circ}\text{C}$ conditions for over 40 hours, with battery system temperature reaching $-22\text{ }^{\circ}\text{C}$. Then tests were conducted for vehicle cold-starting, all-climate battery heating, air conditioning heating, and defrosting, as well as 20% slope climbing, acceleration, braking, and energy consumption in snow and ice conditions, etc. The results of the parking-heating test are shown in Table 2. The test realized a 6-min rapid self-heating via a temperature increase rate of over $5\text{ }^{\circ}\text{C}/\text{min}$. Energy consumption did not exceed 5% of battery capacity during the low-temperature activation process. Moreover, the battery did not need to be heated during the running of the vehicle.

2.2 High-efficiency integrated heat pump air conditioning

In fuel vehicles, air conditioning heats the cabin using the residual heat of the engine as a heat source. However, when an electric vehicle is heated in winter, the utilized heat source is limited, and only the positive temperature coefficient thermistor heating can be used. Studies show that when air conditioning is turned on, the mileage of new energy vehicles decreases by 17% on average in high-temperature environments of $35\text{ }^{\circ}\text{C}$, but decreases by a full 41% on average in cold environments of $-7\text{ }^{\circ}\text{C}$, compared to mileage in a comfortable environment of $24\text{ }^{\circ}\text{C}$ [5]. Air conditioner energy consumption in extreme temperatures seriously limits the mileage of electric vehicles. Aiming at this problem, scholars have proposed various solution including heat pump air conditioning and other solutions [7,8]. Traditional heat pump air conditioning has the characteristics of high-energy efficiency and remarkable energy savings, with a wide range of application. However, the disadvantages of inefficiency at low temperatures, technological difficulties, complex structure, and low heating speed remain.

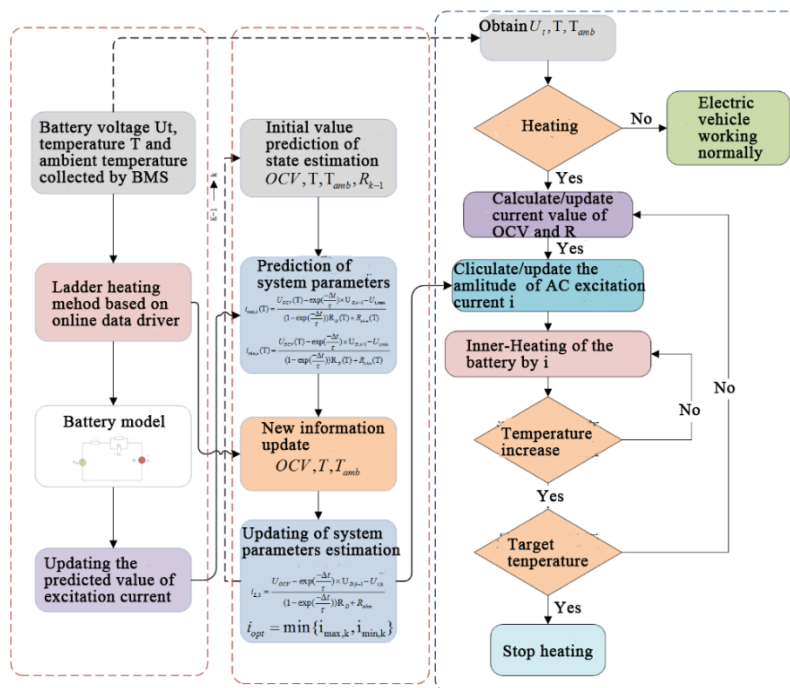

Fig. 6. Control strategy of stepped heating for all-climate battery.

Note: BMS refers to battery management system; OCV refers to open-circuit voltage.

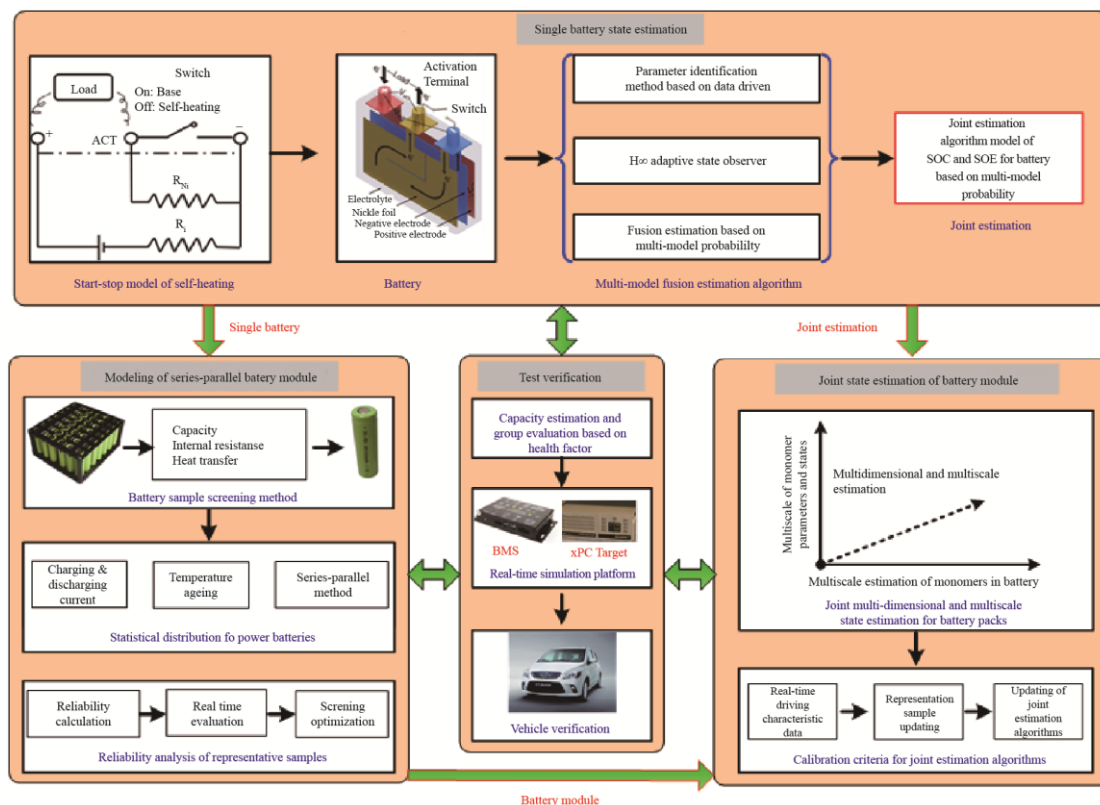

Fig. 7. Comprehensive physical model of all-climate battery system.

Note: SOE refers to state of energy; BMS refers to battery management system.

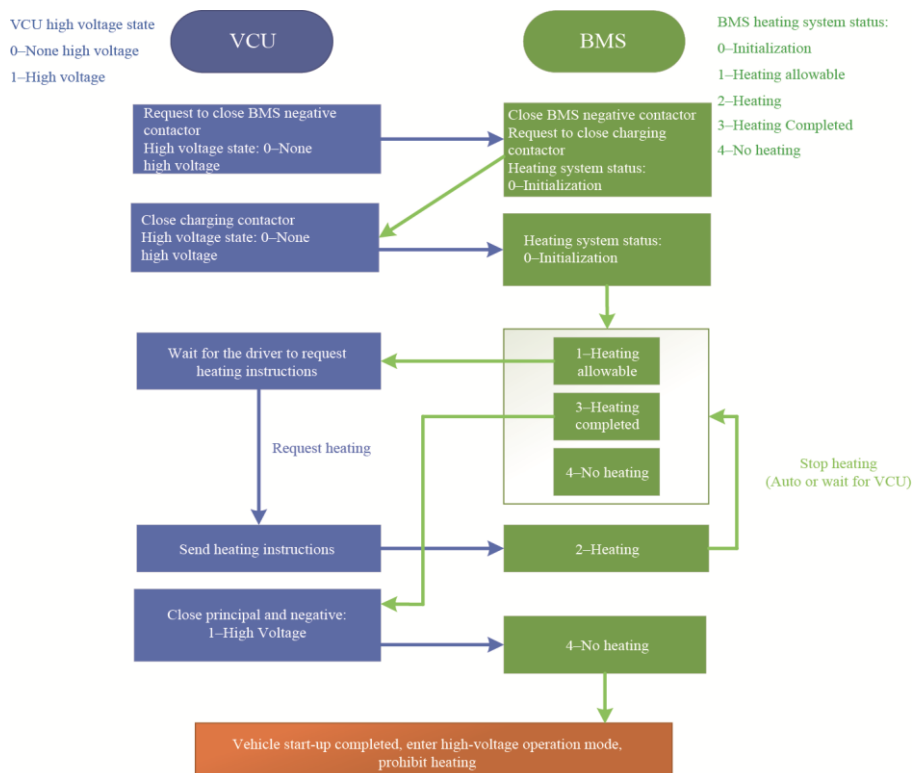

Fig. 8. Human-computer interactive interface.

Note: VCU refers to vehicle control unit; BMS refers to battery management system.

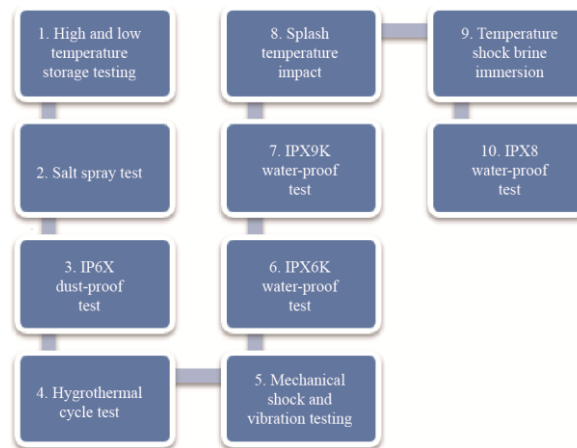

Fig. 9. Design and Test of sustainable protection.

Table 2. Parking-heating test results.

| Test condition | 12 m electric bus | Electric passenger vehicle |
|--------------------------------------|--|---|
| Environment temperature | -37 °C | -23 °C |
| Battery initial temperature | -17 °C /-25 °C | -13 °C/-20 °C |
| Initial SOC | 86.4% | 88.8% |
| Heat ending SOC | 75.2% | 85.2% |
| Heat time (from heat on to heat off) | 8 min | 4 min |
| | (Cell minimum temperature 1 °C, temperature rise rate 3.25 °C/min) | (Cell minimum temperature 1 °C, temperature rise rate 5.2 °C/min) |

To solve this problem of high-energy consumption by electric vehicle air conditioning, in this paper we develop low-temperature air supply and enthalpy-enhanced heat pump air conditioning technology. This technology has the advantages of a wide range of working temperatures, high-energy efficiency, and excellent safety. By solving the air conditioning problems of working temperature limits and low-energy efficiency, this technology would be suitable for application to new energy vehicles.

Fig. 10 shows the technical scheme of high-efficiency integrated heat pump air conditioning with low-temperature air supply and enthalpy-enhanced technology. The working principle to increase enthalpy uses two-stage throttling, intermediate jet technology, and a flash evaporator to separate gas and liquid. Meanwhile, when the heat exchange passes through the medium and low pressure, the air is mixed and cooled while being compressed. The air is then normally compressed at high pressure to increase the displacement of the compressor, thereby achieving the purpose of improving the heating capacity in a low-temperature environment.

We carried out a simulation of this quasi-two-stage compression heating cycle, including analysis of the influence of the opening of the injection tube expansion valve to the two-stage compression heating cycle. The air conditioning enthalpy-enhanced heat pump was optimized and the heating cycle optimization method is obtained. This analysis revealed the influence of refrigerant injection on system cycle parameters, allowing us to obtain the injection law based on the optimal energy efficiency.

Based on the above research, the present paper developed the prototype of heat pump air conditioning systems and reports results of the corresponding tests. **Fig. 11** shows the prototype of electric bus, high-efficiency, electric-integrated air conditioner, and testing devices. In the low-temperature air conditioning and heating test, vehicle temperature rose from -30 °C to 19 °C within 30 minutes. With conditions setting to -20 °C outside and 20 °C inside, the heating energy efficiency ratio reached 1.64. At 35 °C outside and 27 °C inside, the heating energy efficiency ratio reached 3.0. Quick start and high-efficiency operation at low temperature were realized. **Table 3** shows the technical index describing the heat pump air conditioning results.

After a series of theoretical innovations, simulation optimizations, and program improvements, high-efficiency integrated heat pump air conditioning with low-temperature air supply and enthalpy-enhanced technology could solve the existing technical contradiction between heating/cooling effects and energy consumption. This possibility answers the vehicle application need of high-efficiency, low-energy consumption.

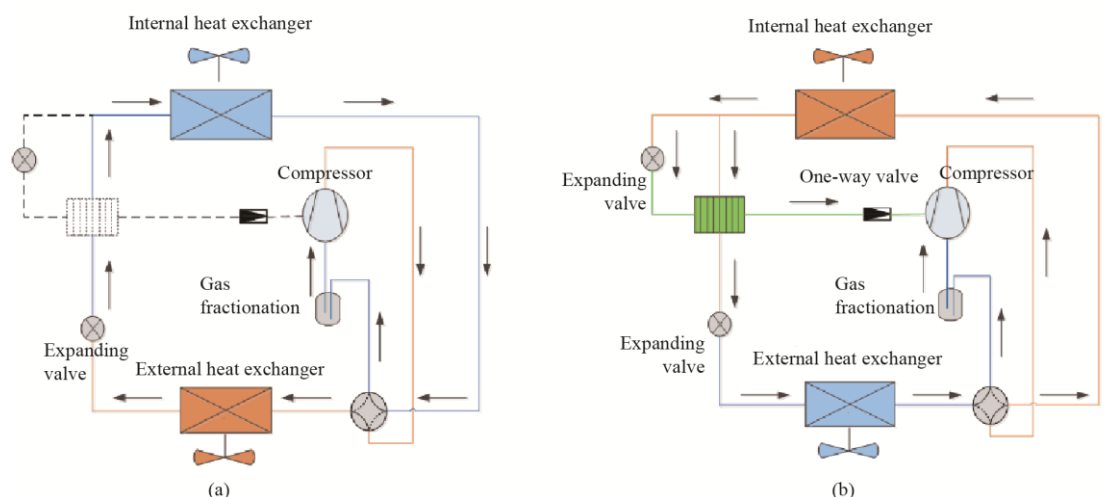

Fig. 10. High-efficiency integrated heat pump air conditioning.



Fig. 11. Low-temperature air source heat pump prototype and testing device for electric bus.

Table 3. Technical index of heat pump air conditioning system.

| | |
|------------------------|---|
| Wide temperature range | All-climate condition (environment temperature: $-20\sim 40\text{ }^{\circ}\text{C}$) |
| High-energy efficiency | heating energy efficiency ratio ≥ 1.6 (outside $-20\text{ }^{\circ}\text{C}$, inside $20\text{ }^{\circ}\text{C}$) cooling energy efficiency ratio ≥ 3.0 (outside $35\text{ }^{\circ}\text{C}$, inside $27\text{ }^{\circ}\text{C}$) |

2.3 Vehicle thermal insulation technology

High-temperature heat dissipation and low-temperature insulation of all-climate new energy vehicles directly affects energy consumption and vehicle mileage. We studied new thermal insulation technologies of all-climate new energy vehicles from two perspectives: heat transfer path and heat generation. In both cases, we use thermal insulation material and extra heat sources to realize the thermal insulation of the vehicle.

Vehicles adopt nano-porous aerogel insulation material for heat insulation to reduce the heat transfer between the interior of the vehicle and the environment, and to reduce the heat loss from the vehicle body. Nano-porous aerogel as a kind of gaseous dispersion medium can be applied to thermal insulation materials. It consists of colloidal particles or high polymer molecules aggregated together to form a network of nano-porous materials, as shown in Fig. 12. The hole size and skeleton size of aerogel materials are nanometer-scale, with the typical size of

a hole being 1 nm–100 nm. The hole rate can reach 80%–99.8%, specific surface area 200–1000 m²/g, and density 3 kg/m³. This material and its optimizations have the advantage of stable nano-porous structure and small thermal conductivity (less than 0.03 W/(m·K)).

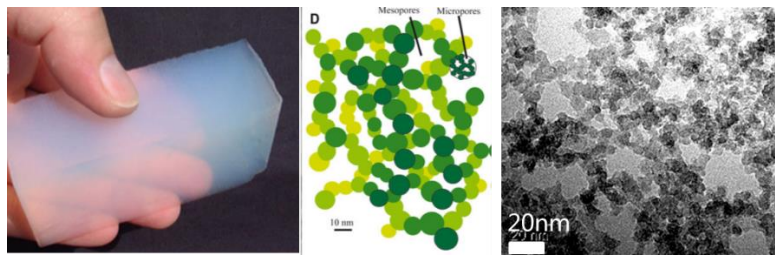

Fig. 12. Nano-porous aerogels.

Vehicle glass heat-insulation material is applied to low-radiation heat-insulation glass. Fig. 13 shows its heat transfer characteristics. By adding a vacuum layer, low-radiation heat-insulation glass can reduce heat transfer. At the same time, the inner wall plating low-radiation film can drastically reduce radiation heat. The glass has the advantages of minimal thermal conductivity, good heat insulation, sound absorption, and temperature maintenance for the vehicle interior in cold conditions, thereby reducing air conditioning power consumption and saving energy.

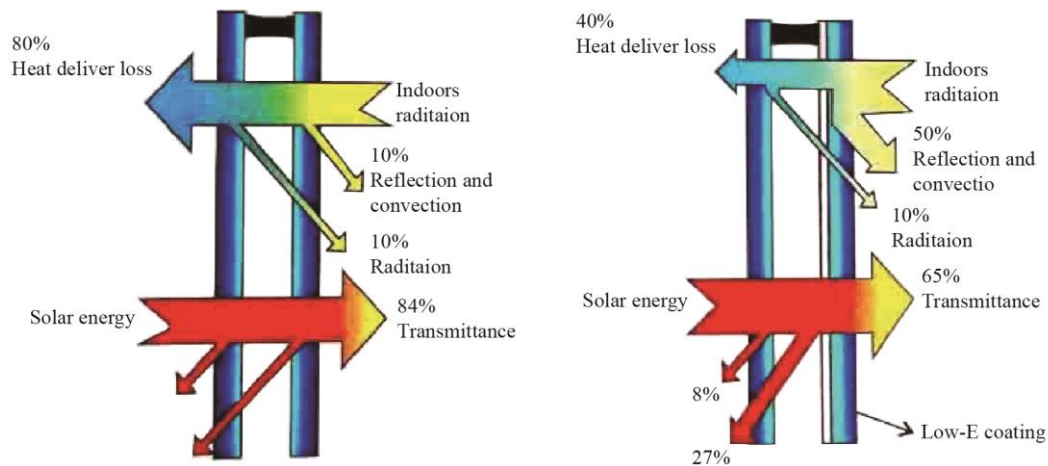

Fig. 13. Heat transfer characteristics of low-radiation insulating glass.

In addition, graphene electric heating film is installed inside the vehicle to realize the insulation of the vehicle body. As shown in Fig. 14, graphene electric heating film has the function of interior heating with infrared radiation, small thickness, space-saving, and high-energy efficiency. The film is evenly heated in a face shape that can be heated to produce low-temperature radiation, avoiding overheating. The film does not emit any harmful gases and is non-toxic, achieving optimal heating effects through the control system.

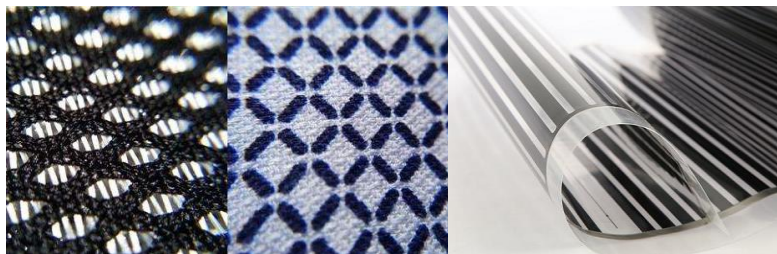

Fig. 14. Graphene electric heating film.

Comprehensive use of aerogel insulation, low-intensity insulating glass, and graphene electric heating film reduces energy consumption while maintaining vehicle temperature. These advances are useful for improving the driving performance of the vehicle and contributing to the global promotion of pure electric buses.

3 Prospects for all-climate new energy vehicle technology

To promote the large-scale application of all-climate new energy vehicles, it is essential to carry out technical optimization and industrialization research based on the above-mentioned key technology prototypes.

3.1 Integrate the high-temperature liquid cooling method and low-temperature self-heating technology, to truly realize “no restricted operation in any climate” for new energy vehicles.

At present, new energy vehicles mostly adopt liquid-cooled heat dissipation to solve the problem of battery heat dissipation in high-temperature environments. The advantages of liquid-cooled systems are the fast cooling speed, good temperature uniformity, and simple and accurate control of fluid (temperature and flow rate). Battery self-heating is an innovative technology for application in environments of extreme cold. Therefore, in order to apply the new energy vehicle to environments of both high and extremely low temperature, it is necessary to further integrate the high-temperature liquid cooling method with the self-heating technology. Through cooling and heating, the battery pack is maintained within a certain temperature range, thereby ensuring that the electric motor, battery, and electronic control system of the electric vehicle operate normally in an all-climate environment.

3.2 Break through low-temperature forbidden area and promote the industrialization of all-climate batteries

Self-heating battery technology innovatively solves the problem of low-temperature battery performance deterioration, but industrialization remains a distant goal. So it is very important to improve all-climate battery safety while reducing cost. Before the full promotion of self-heating batteries, it is necessary to optimize the material selection and manufacturing process of the heating film while strengthening research on the factors affecting battery safety performance.

3.3 Increase the heating rate of high-efficiency integrated heat pump air conditioning

At present, high-efficiency integrated heat pump air conditioning has the characteristics of wide temperature range and high-energy efficiency, but the heating rate of heat pump air conditioning is not high enough in the actual prototype test. Therefore, the key research in the future is finding a suitable match between system energy consumption and heating rate.

3.4 Develop equipment and efficient production technology to help large-scale promotion of new energy vehicles

Some production processes of all-climate new energy vehicles have been greatly altered with respect to traditional vehicles, and corresponding equipment needs to be developed and optimized at the same time. Examples include thermal composite insulation film, welding and packaging equipment, vehicle insulation materials, and other supporting production equipment and processes. These improvements will reduce manufacturing costs and improve battery consistency and vehicle safety.

4 Conclusion

The all-climate new energy vehicle is a model of comprehensive integration and application of a number of technologies, including self-heating battery and system design; high-efficiency, low-temperature, enthalpy-enhanced heat pump air conditioning; vehicle insulation; and other innovative technologies. This combination solves a number of technical problems: inability of new energy vehicles to charge and discharge, inability to start in extremely cold environments, high-energy consumption of air conditioning etc. Technological improvements allow the vehicle to operate normally at a wide range of environmental temperatures, from $-40\text{ }^{\circ}\text{C}$ to $60\text{ }^{\circ}\text{C}$. Project results have been tested in low-temperature environments and will be applied in the low-temperature environment of the Beijing 2022 Olympic Winter Games so as to promote the application of all-climate new energy vehicles in China and even overseas.

References

- [1] China Academy of Engineering Science and Technology Development Strategy. China strategic emerging industries

- development report 2019 [M]. Beijing: China Science Publishing & Media Ltd., 2018. Chinese.
- [2] Ryo K, Yuta A, Yuji Y, et al. Thermophysical properties of trimethylolethane (TME) hydrate as phase change material for cooling lithium-ion battery in electric vehicle [J]. *Journal of Power Sources*, 2019 (427): 70–76.
- [3] Sun H G, Dixon R. Development of cooling strategy for an aircooled lithium-ion battery pack [J]. *Journal of Power Sources*, 2014 (272): 404–414.
- [4] National Big Data Alliance of New Energy Vehicles, China Automotive Technology and Research Center Co., Ltd., Chongqing Chang'an New Energy Vehicle Co., Ltd. Annual report on the big data of new energy vehicle in China (2018) [M]. Beijing: Social Sciences Academic Press (China), 2018. Chinese.
- [5] Edmonds E. AAA research finds HVAC use in frigid temperatures causes substantial drop in electric vehicle range [R]. Chicago: American Automobile Association, 2019.
- [6] Wang C Y, Zhang G S, Ge S H, et al. Lithium-ion battery structure that self-heats at low temperatures [J]. *Nature*, 2016 (529): 515–518.
- [7] Onda K, Masuda T, Nagata S, et al. Cycle analyses of thermoelectric power generation and heat pumps using the β'' -alumina electrolyte [J]. *Journal of Power Sources*, 1995 (55): 231–236.
- [8] Amanda J P, Gregory N, Sanford K. Research on ground source heat pump design [R]. West Lafayette City: Purdue University, 2010.