



Research
Nuclear Power—Review

In-Vessel Melt Retention of Pressurized Water Reactors: Historical Review and Future Research Needs

Weimin Ma^{a,*}, Yidan Yuan^a, Bal Raj Sehgal^{b,*}

^a China Nuclear Power Engineering Co. Ltd., Beijing 100840, China

^b Royal Institute of Technology (KTH), Stockholm 106 91, Sweden

ARTICLE INFO

Article history:

Received 9 November 2015

Revised 14 February 2016

Accepted 1 March 2016

Available online 31 March 2016

Keywords:

Pressurized water reactor

Severe accident

In-vessel melt retention

Debris formation

Debris remelting

Melt pool formation

Melt pool thermal-hydraulics

Critical heat flux

ABSTRACT

A historical review of in-vessel melt retention (IVR) is given, which is a severe accident mitigation measure extensively applied in Generation III pressurized water reactors (PWRs). The idea of IVR actually originated from the back-fitting of the Generation II reactor Loviisa VVER-440 in order to cope with the core-melt risk. It was then employed in the new designs such as Westinghouse AP1000, the Korean APR1400 as well as Chinese advanced PWR designs HPR1000 and CAP1400. The most influential phenomena on the IVR strategy are in-vessel core melt evolution, the heat fluxes imposed on the vessel by the molten core, and the external cooling of the reactor pressure vessel (RPV). For in-vessel melt evolution, past focus has only been placed on the melt pool convection in the lower plenum of the RPV; however, through our review and analysis, we believe that other in-vessel phenomena, including core degradation and relocation, debris formation, and coolability and melt pool formation, may all contribute to the final state of the melt pool and its thermal loads on the lower head. By looking into previous research on relevant topics, we aim to identify the missing pieces in the picture. Based on the state of the art, we conclude by proposing future research needs.

© 2016 THE AUTHORS. Published by Elsevier LTD on behalf of Chinese Academy of Engineering and Higher Education Press Limited Company. This is an open access article under the CC BY-NC-ND license (<http://creativecommons.org/licenses/by-nc-nd/4.0/>).

1. Introduction

Nuclear power safety involves estimating the risks posed by one or more nuclear power plants (NPPs) to the public at large and the efforts to reduce these risks. The populace of most concern is that residing in the vicinity of an NPP; populations in other locations that could be affected by an accident in an NPP are also considered. The basic goal of nuclear power safety is to ensure that an NPP will not contribute significantly to individual and societal health risks. This goal translates to the prevention of the release of radioactivity into the environment from the power plant. A complementary aim is to prevent damage to the plant and to protect the personnel at the plant from injury or death in an accident.

To meet this safety goal, the general configuration of a pressurized water reactor (PWR) plant provides three important physical

barriers to the release of fission products into the environment: the cladding on the fuel element, which contains the fission products generated in the fuel; the reactor vessel, which contains all the fuel elements forming a reactor core; and the leak-tight containment, which is intended to keep any fission products inside the containment from escaping to the environment. Assuring the integrity of each of these physical barriers in any accident scenario becomes the corner stone of the defense-in-depth approach which is extensively employed in nuclear safety against the release of radioactivity to the environment. During a severe accident, the occurrence of reactor core meltdown may cause the first one or two physical barriers to fail, leading to the release of a certain fraction of fission products (gaseous and solid in the form of aerosol) to the pressure-bearing containment. The fission products may leak into the environment if this last barrier also fails. Thus, one can say that the ultimate goal of nuclear power safety is

* Corresponding authors.

E-mail addresses: mawm@cnpe.cc; balraj@kth.se

<http://dx.doi.org/10.1016/J.ENG.2016.01.019>

2095-8099/© 2016 THE AUTHORS. Published by Elsevier LTD on behalf of Chinese Academy of Engineering and Higher Education Press Limited Company. This is an open access article under the CC BY-NC-ND license (<http://creativecommons.org/licenses/by-nc-nd/4.0/>).

to maintain the containment integrity.

According to the state-of-the-art understanding of severe accidents in a PWR [1], the main threats to containment integrity are as follows:

- (1) Direct containment heating (DCH);
- (2) Ex-vessel steam explosion (EVE);
- (3) Hydrogen combustion (H₂C);
- (4) Containment long term over-pressurization (LOP);
- (5) Containment bypass and leakage (CBL); and
- (6) Basemat melt penetration (BMP).

For the Generation III PWR designs, the above items (1)–(5) are taken care mainly through careful design, construction, operation, and accident management, in order to let their risks to be reduced to as low as reasonably possible. The last item, BMP, concerns the thermo-chemical attack of the decay-heated core melt (corium), which may melt through the reactor pressure vessel (RPV) and then the containment basemat if melt coolability is not achieved. The corium coolability (i.e., preventing melt-through of physical barriers) has been recognized as the “Achilles-heel” of the Generation II or earlier PWR designs [2]. The solutions adopted by Generation III reactors are basically divided into two categories: in-vessel melt retention (IVR) or ex-vessel melt retention (EVR), corresponding to the termination of a severe accident in the RPV or in the containment, respectively. The key strategy of IVR is to arrest and confine the corium in the lower head of the RPV by flooding the reactor pit (cavity), while EVR collects and cools the corium ejected from the RPV in a core catcher placed in the containment. Well-known core catcher designs include the melt spreading and cooling compartment deployed in the containment of the European Pressurized Reactor (EPR) [3] of AREVA, and the crucible-like vessel installed under the RPV of the Russian VVER [4]. EPR plants are currently under construction in Finland, France, and China. The VVER-1000 plant with a core catcher (AES-91) was first built in China and came into operation in 2007.

IVR is preferred in Chinese designs of advanced PWRs: It is adopted in the Generation III and Generation III+ PWR designs, and it is also one of the important features of AP1000, which is under construction at two NPP sites in China, and intended to be intensively built in the near future. Therefore, this paper focuses a historical review of IVR development, and afterward provides a recommendation of future research needs in order to improve the credibility of IVR and enable its application in new PWR designs. This historical review of IVR along with state-of-the-art knowledge of severe accidents in PWRs, serves as a basis and rationale for identifying further research needs.

2. History of in-vessel melt retention (IVR)

It should be noted that in-vessel melt coolability and retention includes three general concepts: ① quenching of the core *in situ*; ② coolability of in-vessel particulate beds; and ③ coolability of the in-vessel melt pool. The first concept, which is the best opportunity to catch the core during its heating-up stage, refers to the introduction of water into the core as soon as the emergency core cooling system (ECCS) is recovered. Core quenching is not a straightforward management action since the steam formed may aggravate the accident by increasing the zircaloy oxidation (leading to the addition of oxidation heat to the core and the release of hydrogen). The key action to reduce the cladding temperature quickly and reduce hydrogen production is to add a large volume of water at a rapid rate. The addition of water to the very hot core can create a particulate debris bed due to the crumbling of some of the hot fuel rods that are chilled by cold water. A particulate debris bed is also formed when the melt from the core drops into the lower head full of water. The coolability of such debris beds

provides the second best opportunity to terminate the accident, since the porous media is much more amenable to cooling than a molten pool. If reflooding the core is impossible, the last resort is to realize the coolability of a molten corium pool in the lower head through external cooling of the RPV. This is the IVR strategy to be discussed hereafter. It should be recognized that the water circuit required for the external cooling of the vessel should be separate from the water circuits that add water to the vessel, and that it must function even in the case of a station blackout.

2.1. Principle of IVR

Fig. 1 shows a conceptual picture of IVR, in which the core melt is finally relocated into the lower head and forms a pool of molten materials heated volumetrically by the decay heat, while the outer surface of the RPV is submerged either completely or at least to a level above the lower head. The coolant flow (normally driven by natural circulation) through the external surface of the RPV keeps the vessel wall cool enough to prevent it from creep failure.

The IVR strategy therefore requires that the decay heat of the melt pool be removed by coolant flow outside the vessel. This translates to the rationale that the angular heat flux (q_w) imposed by the melt pool to the vessel wall should not exceed the limit of the external cooling capacity, that is, the critical heat flux (CHF) of boiling at all points around the lower head, see Fig. 2. Otherwise the integrity of the vessel will be lost, sooner or later, due to a boiling crisis and subsequent escalation of vessel wall

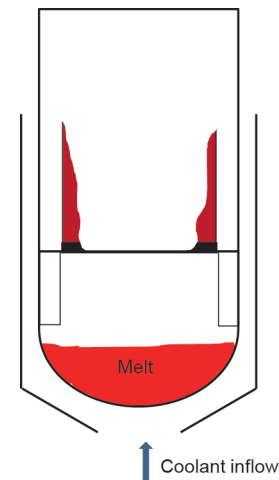

Fig. 1. Sketch of in-vessel melt retention (IVR) by external cooling.

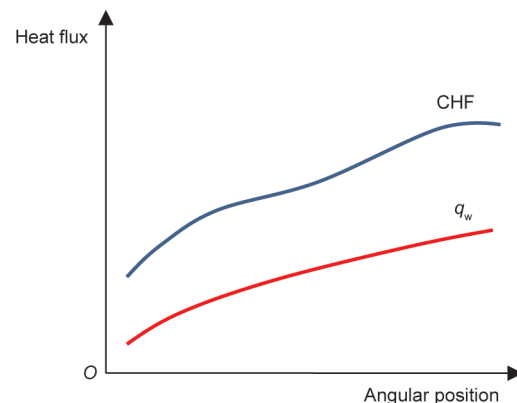

Fig. 2. A comparison of critical heat flux (CHF) and q_w in IVR.

temperature. Although the idea sounds quite simple, it is a formidable task to prove IVR with high confidence. The reason for this difficulty is the challenge of precisely determining either the heat flux or the CHF, and especially the heat flux (q_w) of the melt pool convection which is largely affected by in-vessel severe accident phenomena and accident scenarios. Due to the uncertainties in the understanding of the physical phenomena and accident scenarios, an integrated deterministic/probabilistic approach is introduced, to account for the uncertainties in the assessment of the IVR problem [5] (more details are provided below). The solution is a comparison between probabilities of the heat flux q_w and the CHF, as shown in Fig. 3, where Fig. 3(a) represents a successful case while Fig. 3(b) represents an unsuccessful one.

2.2. IVR of VVER-440

The IVR concept was first proposed in 1989 by Professor Theofanous at the University of California at Santa Barbara (UCSB) as a backfit for the VVER-440 reactors of the Loviisa NPP in Finland [5]. Since the Loviisa containments have relatively low pressure rating and are quite vulnerable to melt attack on the basemat, IVR was conceived during deliberations on a safety upgrade of the plant. The idea is supported by the unique features of the Loviisa reactors: low power density; large water volumes in the primary and secondary circuits, which delay the accident progression; and ice-condenser containments which ensure a flooded reactor cavity due to the melting of ice in most severe accident scenarios. The feasibility of the concept was then jointly investigated by Professor Theofanous and his colleagues at UCSB, as well as by researchers at IVO (the utility company of Loviisa, currently called Fortum). The case for the IVR of the Loviisa plant was submitted to the Finnish regulatory authority—Radiation and Nuclear Safety Authority (STUK), and its implementation was approved by STUK in December 1995.

Both analytical and experimental studies were performed in the extensive research program related to the IVR assessment of the Loviisa plant. To determine the heat flux of the melt pool convection in the lower head, the COPO and ACOPO experiments were carried out by IVO and UCSB, respectively, and correlations were developed to predict the heat flux profile around the lower head. A stratified melt pool having a metal layer above an oxide layer was also considered in the analysis; with the focusing effect, the maximum heat flux from the metal layer is $680 \text{ kW}\cdot\text{m}^{-2}$. The ULPU facility built at UCSB was employed to investigate the external cooling of the RPV, and it was found that the CHF is not less than $1200 \text{ kW}\cdot\text{m}^{-2}$ for a configuration similar to that of the Loviisa plant. Since differences exist between experimentation and reactor application (scaling, simulant vs. prototypic materials, limited scenarios, etc.), the risk-oriented accident analysis methodology (ROAAM) originally developed by Professor Theofanous et al. [6]

was employed in the synthesis of the research results to demonstrate the success of the IVR strategy. The key elements of the ROAAM include a separate treatment of aleatory and epistemic uncertainties; bounding/conservative treatment of intangibles of epistemic uncertainties beyond the reach of reasonably verifiable quantification; and the use of external experts in review rather than in primary quantification. The conclusion was that the thermal loads on the RPV wall from the molten corium pool are far below the level for the occurrence of a boiling crisis on the outer surface of the wall such that melt-through of the RPV is physically unreasonable in all scenarios in which the reactor cavity is flooded. The safety margins are large, so that the undefined uncertainties will not endanger the overall conclusion for the Loviisa plant [5].

2.3. IVR of AP600 and AP1000

The AP600 reactor is an evolutionary Generation III PWR design by Westinghouse, although it has never been built (its successor, AP1000, is fast approaching its first completion in China). The first driving idea behind AP600 is to achieve passive safety, employing natural forces rather than plant control and operator intervention, particularly during abnormal transients and accidents. The principal objective is to meet the increasingly stringent regulatory requirements for plant safety, including severe accident prevention and mitigation. The second driving idea is to reduce the “footprint” of an NPP, by decreasing the materials and equipment, and reducing the construction cost and schedule.

Among the many features of the AP600 design are passive cooling systems, including passive core cooling, passive containment cooling, and an IVR similar to that of Loviisa. The IVR of AP600 uses the water from the in-containment refueling water storage tank (IRWST) to flood the reactor cavity from the bottom, and submerge the reactor vessel up to its cold-leg and hot-leg nozzles. The annulus between the vessel wall and its insulation (or baffle/cavity wall) serves as the riser for the two-phase flow around the vessel. The characteristics of the flow path are crucial to the natural circulation flowrate and the boiling-induced two-phase flow and heat transfer (e.g., CHF) on the outer surface of the vessel.

In contrast to the Loviisa plant which needed backfitting measures (e.g., some changes in RPV insulation) to achieve IVR, the AP600 reactor had the advantage of having an optimal IVR designed for it (e.g., placing the insulation and baffle for better natural circulation) through interactions with its supporting research. The comprehensive study of the IVR for the AP600 reactor [7] was also carried out by Professor Theofanous and his colleagues almost during the same period as the IVR study of Loviisa. Thus, the two studies were carried out largely in parallel—even sharing some of the experimental work and personnel [5].

The study of the AP600 IVR [7] started from scenario descrip-

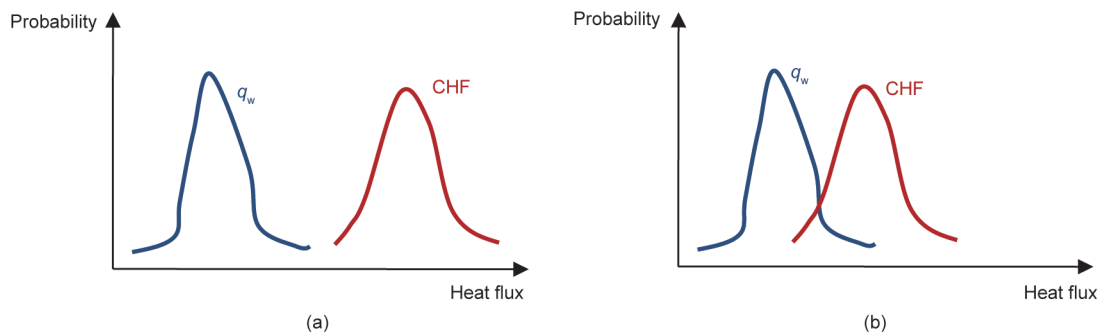

Fig. 3. Heat flux distribution functions. (a) Successful case; (b) unsuccessful case.

tions; in particular, how the melt relocates from the core region to the lower head. It then analyzed the possibility of vessel failure due to ① a melt jet attack on some particular vessel location and ② a steam explosion generated by the melt entry into the water pool in the lower head—although this possibility was concluded to be remote. Finally, the study focused on determining the thermal load on the lower head and the CHF by the external cooling of the RPV. In addition to the insights from other research, ACOPO and ULPU-2000 experiments were carried out at UCSB to investigate the angular heat flux distribution and the CHF, respectively. The ROAM approach was also employed in the IVR study of AP600 for the synthesis of its results (the final assessment for certification). Special attention was paid to the influence of melt pool composition and stratification on the thermal loading on the vessel wall. The metal layer of AP600 would be thick, providing a sufficient margin between the focused heat flux and the CHF outside. It was found that the heat flux varied with angle, peaking near the equator of the lower head. Fortunately, the CHF of the external cooling also reached its highest value ($1.5 \text{ MW}\cdot\text{m}^{-2}$) near the equator. In most considered cases, the ratio of the imposed heat flux to the CHF was below 0.6, and thus the major conclusion was that thermally-induced failure of an externally-cooled AP600 vessel is physically unreasonable. The final design of AP600 was approved in September 1998, and the design certification was issued by the US Nuclear Regulatory Commission (USNRC) in December 1999, although there was no special certification of the IVR concept by the USNRC.

Following this success story, the IVR strategy was incorporated into the AP1000 design by Westinghouse. This design is more or less an enlarged version of AP600, with a power rating of 1000 MW_e . Due to the higher power generation, further work was performed on the technology and methodology of IVR, particularly for the enhancement of the CHF on the outer surface of the vessel, to obtain a sufficient safety margin to cover the uncertainties. To promote IVR, the AP1000 has the following particular design features: ① The reactor coolant system (RCS) is equipped with a multistage, diverse, redundant automatic depressurization system (ADS) to reduce the pressure loading on the reactor vessel wall; ② the lower head of the RPV does not have bottom-mounted instrumentation, to eliminate the potential of a penetration failure (which tends to occur much earlier in time than vessel creep failure, if it occurs); ③ the lower core support plate and lower internals sit low within the reactor vessel lower plenum to ensure that they can be melted by the oxide core debris relocated there, creating a thick metal layer to reduce the focusing effect; and

④ a dedicated baffle system surrounding the lower head, made of reflective metal insulation, is designed to form a cooling annulus to enhance natural circulation flow velocities and, as a result, the CHF. Through the ULPU-2400 experiment [8], which scaled the external cooling flow path of AP1000, it was found that the CHF near the equator of the lower head could reach $2 \text{ MW}\cdot\text{m}^{-2}$, which was considerably larger than the maximum thermal load for AP1000, estimated as $1.3 \text{ MW}\cdot\text{m}^{-2}$ [1]. An independent analysis [9] implied that the thermal load may exceed the CHF under some extreme conditions (e.g., a thin metal layer above the oxide pool, see Fig. 4(a)) but that the probability was very low. Additional parametric calculations were performed for a three-layer configuration on considering the findings of the MASCA projects [10,11]; this configuration involved a molten oxide pool sandwiched between a bottom, heavy metallic layer and a top, light metallic layer (Fig. 4(b)). The results showed that the heat flux of the bottom layer remained well below the CHF from the ULPU-2400 tests. The final design of AP1000 was approved in September 2004, and the design certification was issued by the USNRC in January 2006. China subsequently started building four AP1000 reactors at two sites in 2008.

2.4. IVR of APR1400

The IVR strategy was also adopted by the Korean design of the 1400 MW_e Advanced Power Reactor (APR1400). In addition to external reactor vessel cooling (ERVC), the APR1400 system design plans include the ability to simultaneously flood the metal layer with water inside the vessel after the RCS depressurization; a action that could—hopefully—remove sufficient heat from the upper face of the metal layer to reduce the focused heat flux on the vessel wall to values lower than the CHF (Fig. 5 [12]). A dedicated water system has been installed in the reactor, enabling water injection to reach the melt pool in the lower head at the appropriate time [1]. It must be pointed out that bringing water into the extremely hot vessel at such a point in time is not an easy matter, and would need a comprehensive evaluation and perhaps a demonstration.

In order to understand whether the currently-proposed ERVC and additional enhancements could provide sufficient heat removal for higher-power reactors (up to 1500 MW_e), a collaborative effort was completed in which the Idaho National Laboratory (INL) and Pennsylvania State University (PSU) in the US, and the Korea Atomic Energy Research Institute (KAERI) and Seoul National University (SNU) in Korea jointly investigated the ERVC en-

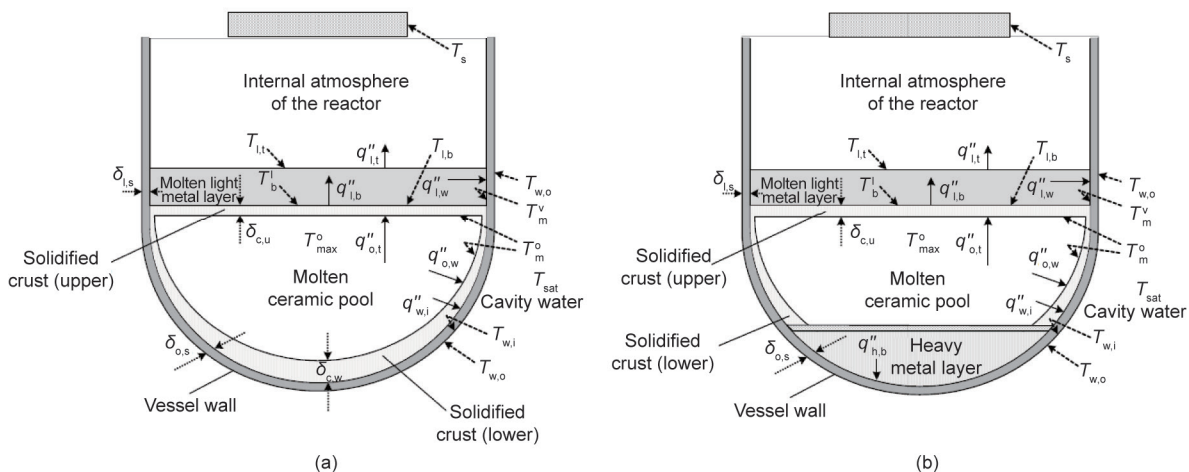

Fig. 4. Schematic of the melt pool configurations in the lower head [9]. (a) Two layers; (b) three layers.

hancements and an in-vessel core catcher (IVCC) [13]. The study included four tasks: ① calculations conducted by SCDAP/RELAP5 to define representative bounding late-phase melt conditions; ② the design of an IVCC; ③ ERVC enhancements; and ④ an assessment of the improved safety margin obtained from the design modifications. The study chose APR1400 as the reference reactor. Several experimental facilities and state-of-the-art analysis codes in the US and Korea were employed to investigate options that could enhance ERVC and IVCC performance. The main findings and conclusions were as follows.

(1) The average thermal loads on the APR1400 lower head were estimated to range from $0.147 \text{ MW}\cdot\text{m}^{-2}$ to $1.64 \text{ MW}\cdot\text{m}^{-2}$ for the considered accident scenarios, in the absence of any ERVC enhancements. The flowrate of natural circulation obtained in the HERMES-HALF facility (a scaled flow path of APR1400 ERVC, injecting air to simulate the boiling effect) could be up to $200 \text{ kg}\cdot\text{s}^{-1}$, at which the CHF near the equator of the lower head could reach $1.3\text{--}1.45 \text{ MW}\cdot\text{m}^{-2}$, based on the SULTAN [14] experiment. Hence, it was observed that employing ERVC alone, without the injection of water into the vessel, is insufficient to remove the decay

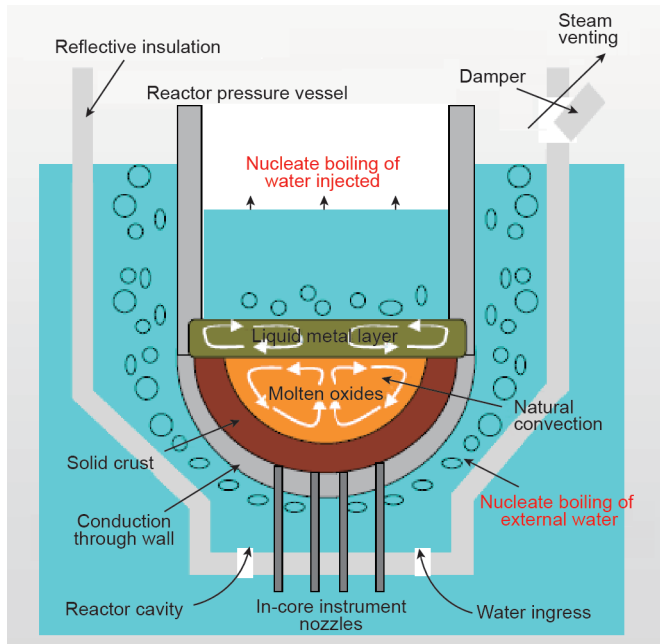

Fig. 5. Schematic of IVR in APR1400 [12].

heat of the melt pool in the lower head and to assure the integrity of the vessel. The study did not mention the influence of top cooling by water injection, but studies elsewhere indicate that top-flooding alone may only be able to cool down a 100–200 mm thick melt layer.

- (2) To support the design of the IVCC (Fig. 6 [13]) for enhancing coolability, experiments were carried out on the GAMMA-2D facility (a slice of semi-circular vessel with outer diameter of 500 mm) to investigate the gap cooling and the CHF at atmospheric pressure which were measured as ranging from $50 \text{ MW}\cdot\text{m}^{-2}$ to $250 \text{ MW}\cdot\text{m}^{-2}$, corresponding to gap sizes of 1 mm, 3 mm, and 5 mm. The melt attack on the core catcher and the refractory coating on its surface were also investigated, but its survival ability, and influence on the RCS have not yet been determined. The IVCC and the water injection into the vessel belong to in-vessel cooling enhancement measures.
- (3) One ERVC enhancement is to modify the originally proposed insulation as shown in Fig. 7 [13] (adding the insulation marked in dark grey), in order to streamline the flow for more effective cooling. This idea is similar to the IVR upgrade from AP600 to AP1000, which redesigned the baffles to obtain a higher CHF. The relevant tests performed on the SBLB facility (with a hemispherical representation of 1/5 scale lower head) showed that the CHF was enhanced by around 20% near the equator of the hemispherical head.
- (4) Another ERVC enhancement is to apply a micro-porous coating on the outer surface of the head using aluminum or copper. It was found that the CHF near the equator of the coated head was around 80% higher than that of the plain head. The micro-porous aluminum coating appeared to be much more durable than the micro-porous copper coating, since it remained intact even after many cycles of steady-state boiling.
- (5) When the modified insulation and the vessel coating were applied together, the integral effect on the CHF near the equator was an increase by a factor of 2.2. It appears that ERVC with the use of vessel coating and a modified insulation structure could provide sufficient cooling for high-power reactors such as APR1400.

The severe accident mitigation strategy of the Korean APR1400 reactor does not appear to be definitively set, and may undergo changes. The questions of how to interpret the experimental data from the small-scale tests and how to apply the coating to the prototypical vessel are still unclear. While the standard APR1400 version uses IVR, it is notable that its modified version for the

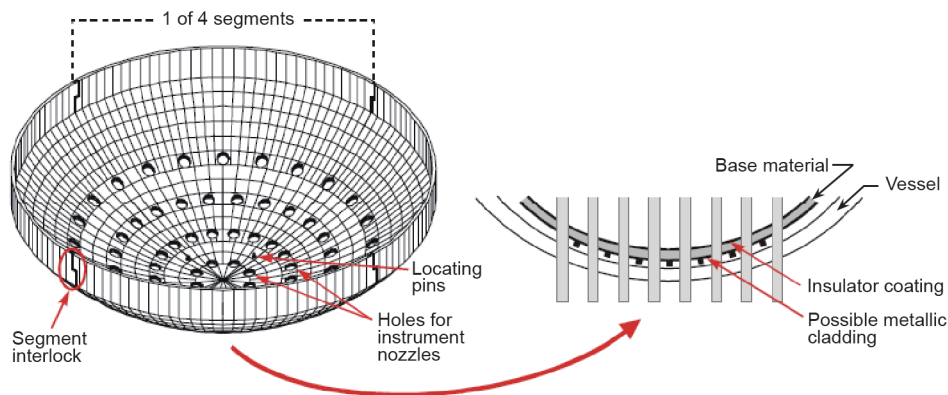

Fig. 6. Conceptual design of the in-vessel core catcher for APR1400 [13].

European market will have an ex-vessel core catcher similar to the basemat-internal melt arrest and coolability (BiMAC) device placed under the RPV of economic simplified boiling water reactor (ESBWR)—a boiling water reactor (BWR) design by GE-Hitachi Nuclear Energy [15].

2.5. IVR of CAP1400 and HPR1000

After the Fukushima accidents, the Chinese nuclear authority took actions to introduce more stringent requirements for nuclear power safety, and new reactors are expected to accomplish the “practical elimination of large radioactive release.” Severe accident prevention and mitigation measures are paramount to reach such a goal. The IVR strategy is preferred in Chinese Generation III PWR designs, following the import of AP1000. HPR1000 and CAP1400 are two such advanced PWRs.

The CAP1400 reactor has a power rating of 1400 MW_e and was developed by the State Nuclear Power Technology Company (SNPTC) of China. It essentially inherited the design philosophy and features of AP1000. Due to its enlarged capacity, a considerable number of research activities have been carried out by SNPTC and its collaborators, including the design and qualification of the IVR. An ULPU-like facility scaled to the CAP1400 was set up at Shanghai Jiaotong University to demonstrate the heat removal capability for external cooling of the reactor vessel. The site of a pilot plant of CAP1400 has been determined and construction work may begin in 2016.

The HPR1000, also called Hualong One, is an advanced PWR with a power of 1000 MW_e, jointly designed by the China National Nuclear Corporation (CNNC) and the China Guangdong Nuclear Power Holding Corp. Ltd. (CGNPC). This reactor also has the advantage of passive safety, being equipped with a passive containment cooling system (PCCS) and a passive residual heat removal system (PRS). However, the IVR strategy of HPR1000 has an “active plus passive” feature, which means that the external cooling of the vessel is driven either by a pump (active) or by a gravity head (passive). The idea behind this concept is to increase the redundancy and safety margin. CNNC and CGNPC have accomplished many R&D studies for HPR1000, incorporating lessons learned from their experiences in design/construction/operating of the existing PWR fleet in China. Construction of the first HPR1000 plant started in May 2015.

Regarding IVR applications in Chinese reactors, extensive research efforts (e.g., Refs. [16–18]) have been carried out in different organizations in China, but most data are not yet available to the public, due to commercial confidentiality.

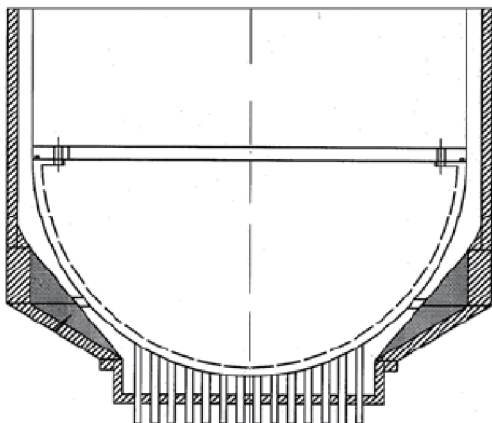

Fig. 7. Schematic of the enhanced insulation [13].

3. Future research needs

From the above descriptions, one can see that the qualification of an IVR measure directly depends on two parameters: the heat flux incident from the melt pool on the vessel wall, and the heat removal capacity of the external cooling of the vessel (i.e., the CHF). The uncertainty in determining the CHF of boiling on the downward-facing vessel surface is relatively low, since one can perform an experimental investigation on the problem with a well-scaled mock-up. Recent efforts are directed toward CHF enhancements by designing an optimal insulation structure surrounding the vessel, streamlining the flow path, and increasing the driving head. CHF enhancements of coated and structured surfaces as well as coolant with surfactant or nano fluid were also investigated and interesting results were obtained; however, the feasibility of their effectiveness for a prototypical RPV during its life-time of perhaps 60–80 years is still an open question.

There are other uncertainties which mainly come from the incident heat flux during the core melt progression to the vessel wall, since in principle all the in-vessel melt progression and phenomena affect it. The Three Mile Island nuclear reactor unit 2 (TMI-2) accident itself provided a vivid example of other possible modes of vessel failure during the late phase of in-vessel accident progression for a PWR [1]. It was found (later) that the vessel wall had almost reached the creeping temperature, while the vessel was full of water. Somehow (it is not known exactly why) the vessel wall cooled down to lower temperatures and vessel integrity was maintained. In this context, of particular interest are: the formation of a large molten pool within the core and the collapse of a large portion of the rods above the pool (forming a debris bed), and the partial corium relocation toward the lower head. Fig. 8 [7] illustrates such an intermediate state of the core-melt progression before its final steady state, which was used as the bounding configuration (Fig. 4) in the past assessment of IVR. Questions may be raised when experts review the bounding configuration because of knowledge gaps on forming the final configuration. Below, we have attempted to give a brief review of the current understanding on debris formation, remelting, the vulnerability of instrument guide tube (IGT) penetrations, and molten pool behavior, all of which play a role in the evolution of the final state of the debris and melt pool in the lower head.

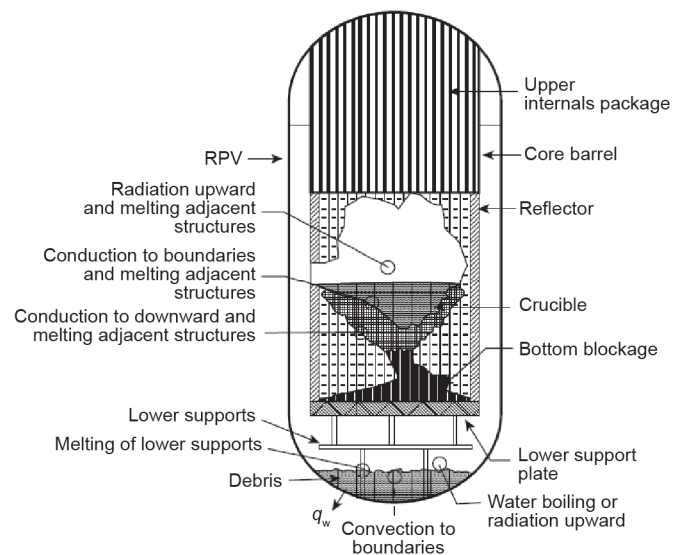

Fig. 8. Intermediate state of melt progression before final steady state [7].

3.1. Debris formation

The core melt that is relocated into the lower head may first form a debris bed due to fragmentation on its settlement in the water pool. The fuel-coolant interaction (FCI) may also lead to a steam explosion. Table 1 shows data from some FARO tests [19,20] investigating corium jet breakup and quench during the penetration of molten corium into a water pool. Most of the tests employed more than 100 kg of a melt mixture of 80% UO_2 -20% ZrO_2 in a saturated water pool, meaning that they are mainly designed for the in-vessel particulate debris formation case. It was found that the debris did not uniformly spread on the bottom, and heap-like debris beds were obtained. Various particle shapes were observed, with sizes varying between 0.25–11 mm (Table 1 shows the mean particle sizes). An important finding was the formation of cakes. The worst case for the test is L-19, where the cake mass is about 50% of the total corium released in the melt jet. The formation of cake is important to debris coolability, yet, the degree of its influence is not completely clear; nor is it clear when and how such cake formation may occur. FARO also showed a considerable amount of hydrogen generation, indicating that a chemical reaction took place and affected the debris formation.

Due to difficulties in performing and controlling experiments with prototypical materials, simulant materials with lower melting points were extensively employed in experiments. Such an approach is necessary for better understanding of the physics of fuel-coolant interactions. However, most existing studies (including those with prototypical materials) were focused on the melt breakup mechanism, mixing, and FCI energetics. Little data exists on debris bed formation, which is of significance to debris bed coolability. The DEFOR program launched at KTH is trying to fill this gap [21]. A number of experiments have already been performed with simulant materials providing results on particle size distribution similar to those observed in the FARO tests. The debris agglomeration phenomenon was also observed in some tests using simulant materials.

Once a debris bed is formed, the debris bed coolability is important. Compared with debris bed formation, the debris bed coolability is much better understood due to many analyses and experimental studies. Although the characteristics of a prototypical debris bed and their influence on coolability are not completely clear yet [22], the current understanding is that the debris bed formed in the lower head is uncoolable, and will remelt.

3.2. Debris remelting

Debris remelting is almost an unexplored research area, although it is important to the formation of the final molten pool in the lower head. The reason for this importance is that during the dynamic process of debris remelting, many intermediate states

could occur, whose thermal loads may not be always below the upper limit of heat removal with external cooling. For example, due to their lower melting points, the metallic components of the debris could melt first and form a liquid metal pool. The solid debris (oxide components) with higher melting points would then be submerged in the metal pool, as illustrated in Fig. 9. This configuration has a thinner metal layer above a debris bed, and may increase the focusing effect.

Another concern about the vessel failure in the attack of the debris (or melt) on the IGT is weldings and penetrations. This concern is for the PWRs which employ such IGTs inserted from the bottom of the vessel. The IGTs could have welds, inside the bottom head which could be vulnerable to creep failure during the debris heat-up. The IGTs could be possibly ejected of the bottom head and open a path to melt discharge from the bottom head, i.e., a failure of the vessel.

3.3. Molten pool behavior

Molten pool heat transfer is a very hot research topic, since it determines the thermal load on the reactor vessel. Several experimental studies have been performed—such as COPO [23], ACOPO [24], SEMICO [25], and LIVE [26]—on the natural convection of a volumetrically heated pool using different simulant liquids for representing corium, such as water, organic fluids, a molten binary mixture (KNO_3 - NaNO_3), and so forth. The objective was to obtain correlations of the heat transfer coefficients, so as to use them in the IVR assessment. The RASPLAV [27] and MASCA [10] studies used prototypical materials on small scales. The main limitation of the existing experiments is that their Rayleigh numbers are much lower than the prototypical ones, mainly due to the small scale of the test facilities. The BALI [28] experiment reached a high Rayleigh number due to its radius being equal to that of a PWR vessel. It used organic fluid as a simulant for melt in its slice geometry. The recent COPRA study [29], sponsored by the China Nuclear Power Engineering Co. Ltd. (CNPE), also had a prototypical scale and used a binary mixture of KNO_3 - NaNO_3 . In general, since various scaled facilities and fluids were used in the above-mentioned studies, the experimental data have scatter, and care must be taken in applying them to prototypical conditions. There is a clear need to perform new experiments that have a higher temperature and Rayleigh number.

Another issue of melt pool behavior is stratification. Since the metal phase (Zr and Fe) in the core melt is lighter than the oxide mixture (UO_2 - ZrO_2), a two-layer melt pool was conceived first in the study on melt pool heat transfer. The projects RASPLAV and the MASCA of Organization for Economic Co-operation and De-

Table 1
Initial conditions and key characteristics of FARO tests [19,20].

| Parameter | Test | | | | | | | | |
|--|------------------|------|------|------|------|------|------|------------------|------|
| | L-06 | L-08 | L-11 | L-14 | L-19 | L-20 | L-24 | L-27 | L-28 |
| Corium mass (kg) | 18 | 44 | 151 | 125 | 157 | 96 | 176 | 129 | 175 |
| Jet diameter (cm) | 10 | 10 | 10 | 10 | 10 | 10 | 10 | 10 | 5 |
| Water pool depth (m) | 0.87 | 1.00 | 2.00 | 2.05 | 1.10 | 1.97 | 2.02 | 1.47 | 1.44 |
| Water temperature ($^{\circ}\text{C}$) | SAT ^a | SAT | SAT | SAT | SAT | SAT | SAT | SAT | SAT |
| Initial pressure (bar ^b) | 50 | 58 | 50 | 50 | 50 | 20 | 5 | 5 | 5 |
| Free fall (m) | 1.66 | 1.53 | 1.09 | 1.04 | 1.99 | 1.12 | 1.07 | Nya ^c | Nya |
| Cake on bottom (kg) | 6 | 14 | 0 | 20 | 80 | 21 | Nya | 31 | 0 |
| Mean particle size (mm) | 4.5 | 3.8 | 3.5 | 4.8 | 3.7 | 4.4 | 2.5 | Nya | Nya |

^a Saturated.

^b 1 bar = 100 kPa.

^c Not yet available or no data in related publications.

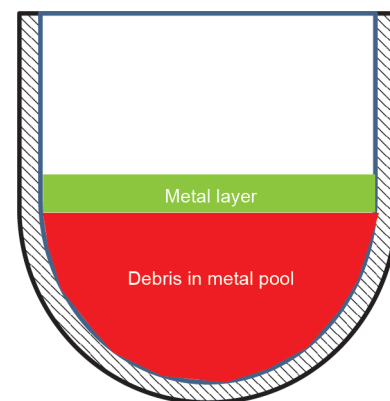

Fig. 9. A possible configuration for debris bed with heat generating oxidic debris in a metal melt pool.

velopment (OECD) found that element partitioning occurring due to chemical reactions between molten metal and oxides layers in a corium pool may create other melt pool configurations. For example, the MASCA project found that combination of the steel components with uranium can form a metal compound that is heavier than the oxide pool material. This “heavy metal” may sink to the bottom of the oxide-rich melt pool. This important finding implied the possibility of layer inversion and the formation of a three-layer pool with an oxide layer between the bottom and top metal layers in the lower head, as shown in Fig. 10. The worst consequence of such configuration would be a stronger focusing effect, since some of the steel at the top would be taken by uranium to the bottom of the pool. The initiator of the layer inversion is the non-oxidized zirconium present in the melt, but some data obtained in the oxidizing atmosphere (steam) showed that once the zirconium oxidation was complete the steel was released from uranium and rose back to the top of the pool [1]. Thus, our current understanding on corium pool composition and configuration is quite confused, and more research on the issue of pool stratification should be performed. The points to be addressed are: ① the partitioning kinetics and integrity/diffusion resistance of crust between the layers; ② the effect of temperature differences between layers; ③ the history of core degradation and relocation into the lower plenum; and ④ oxygen diffusion from steam supply to the pool surface, to the interior of the melt pool, specifically to the heavy metal layer near the bottom of the pool. In this context, it is important to determine the time period between the formation of the heavy metal layer and the release of steel from the heavy metal layer. If the time period is short, the increased heat flux from the thinner metal layer at the top (being greater than the CHF on the outside surface of the vessel) may still not cause the vessel to fail. However, if the time period is long, vessel failure at the azimuthal location of the upper metal layer may become certain. Research needs to be performed to obtain sufficient knowledge about the interactive phenomenon of oxygen diffusion and the movement of steel between the lower metal layer and the upper metal layer.

Finally, the IVR assessment also involves: ① the coupling of the melt pool convection, vessel wall heat conduction, and external boiling heat transfer; ② the vessel wall creep under high temperature and its interaction with the melt pool; and ③ thermochemical erosion. These factors are all poorly understood.

4. Concluding remarks and outlook

IVR of the core melt by external cooling of the RPV is extensively adopted, both in existing plants as a backfit and in new reactor designs (so-called Generation III reactors), including

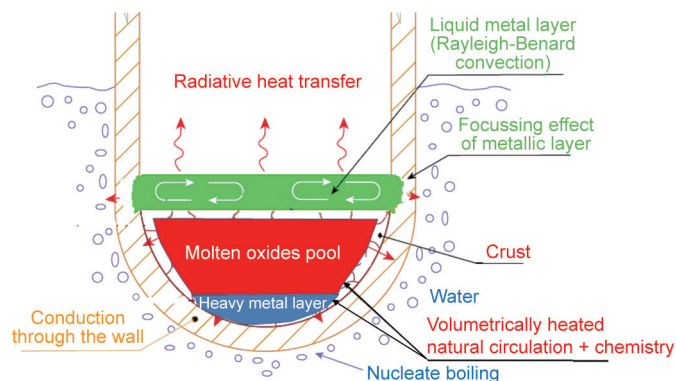

Fig. 10. Phenomena of IVR.

VVER-440, AP1000, APR1400, HPR1000, and CAP1400. IVR is well-accepted as an effective severe accident mitigation measure for the safety goal of “practical elimination of large radioactive release.” A large number of concerted efforts has been conducted worldwide to find design solutions that ensure core melt coolability and retention, and also to gain knowledge regarding the melt-pool-induced thermal load to the vessel wall and the CHF of boiling on the outer surface of the RPV—two key parameters in the assessment of the effectiveness of IVR design. However, some gaps and uncertainties still exist, especially in scenarios of in-vessel melt evolution, for which the TMI-2 accident remains the sole point of reference.

We propose the following research topics to further reduce these uncertainties and to complete our knowledge base:

- Melt relocation from the core to the lower plenum with a focus on debris formation and remelting;
- Debris remelting and molten pool formation from an uncoolable debris bed;
- Melt pool convection under more prototypical conditions (e.g., high temperature, high Rayleigh number, oxides);
- Mechanisms of melt pool stratification, pool dynamics along with definitions of melt pool chemistry and oxygen diffusion kinetics, and possible melt pool configurations during a severe accident;
- Coupled analysis and experimentation of the melt pool convection, vessel wall heat conduction, and external boiling heat transfer;
- Enhancements of external cooling and their applications to reactor designs, and other coolability enhancement measures.

We believe that ongoing research in China and abroad (such as the IVMR and SAFEST projects in the European Union (EU)) will significantly advance our confidence in the IVR strategy. It will be very interesting to determine, through our research efforts, the upper limit of IVR in terms of the power level of reactors, thus guiding reactor designs and facilitating the licensing process. Moreover, further research work will enrich our knowledge base on severe accident, which does not only help to certify the suitability of our reactor designs and severe accident management strategies, but also provide solutions for important unresolved issues in reactor safety, thereby increasing the acceptability of nuclear power to the public.

Compliance with ethics guidelines

Weimin Ma, Yidan Yuan, and Bal Raj Sehgal declare that they have no conflict of interest or financial conflicts to disclose.

References

- [1] Sehgal BR. Nuclear safety in light water reactors: severe accident phenomenology. Waltham: Academic Press; 2012.
- [2] Sehgal BR. Stabilization and termination of severe accidents in LWRs. Nucl Eng Des 2006;236(19–21):1941–52.
- [3] Fischer M, Herbst O, Schmidt H. Demonstration of the heat removing capabilities of the EPR core catcher. Nucl Eng Des 2005;235(10–12):1189–200.
- [4] Bezlepkin VV, Kukhtevich IV, Leont'ev YG, Svetlov SV. The concept of overcoming severe accidents at nuclear power stations with VVER reactors. Therm Eng 2004;51(2):115–23.
- [5] Kymäläinen O, Tuomisto H, Theofanous TG. In-vessel retention of corium at the Loviisa plant. Nucl Eng Des 1997;169(1–3):109–30.
- [6] Theofanous TG, Najafi B, Rumble E. An assessment of steam-explosion-induced containment failure. Parts I: probabilistic aspects. Nucl Sci Eng 1987;97(4):259–81.
- [7] Theofanous TG, Liu C, Additon S, Angelini S, Kymäläinen O, Salmassi T. In-vessel coolability and retention of a core melt. Nucl Eng Des 1997;169(1–3):1–48.
- [8] Dinh TN, Tu JP, Salmassi T, Theofanous TG. Limits of coolability in the AP1000-related ULPU-2400 Configuration V facility. In: Proceedings of the 10th International Topical Meeting on Nuclear Reactor Thermal Hydraulics;

- 2003 Oct 5–9; Seoul, Korea; 2003.
- [9] Esmaili H, Khatib-Rahbar M. Analysis of in-vessel retention and ex-vessel fuel coolant interaction for AP1000. Rockville: Energy Research, Inc.; 2004 Aug. Report No.: NUREG/CR-6849.
- [10] Asmolov V, Tsurikov D. Major activities and results. In: Material Scaling Seminar; 2004 Jun 10–11; Aix-en-Provence, France; 2004.
- [11] Tsurikov D. MASCA2 Project: major activities and results. In: Material Scaling Seminar; 2007 Oct 11–12; Cadarache, France; 2007.
- [12] Oh SJ, Kim HT. Effectiveness of external reactor vessel cooling (ERVC) strategy for APR1400 and issues of phenomenological uncertainties. In: Workshop Proceedings: Evaluation of Uncertainties in Relation to Severe Accidents and Level-2 Probabilistic Safety Analysis; 2005 Nov 7–9; Aix-en-Provence, France; 2005.
- [13] Rempe JL, Suh KY, Cheung FB, Kim SB. In-vessel retention strategy for high power reactors. Idaho Falls: Idaho National Engineering and Environmental Laboratory; 2005 Jan. Report No.: INEEL/EXT-04-02561.
- [14] Rougé S. SULTAN test facility for large-scale vessel coolability in natural convection at low pressure. Nucl Eng Des 1997;169(1–3):185–95.
- [15] Theofanous TG, Dinh TN. Integration of multiphase science and technology with risk management in nuclear power reactors. Multiphas Sci Technol 2008;20(2):81–211.
- [16] Cheng X, Yang YH, Ouyang Y, Miao HX. Role of passive safety systems in Chinese nuclear power development. Sci Technol Nucl Ins 2009;2009:573026.
- [17] Tang CL, Kuang B, Liu PF, Zhu C, Wang F. Preliminary analysis of channel flow characteristics in the passive IVR-ERVC experimental facility. Nucl Tech 2014;37(12):120604. Chinese.
- [18] Li YB, Tong LL, Cao XW, Guo DQ. In-vessel retention coolability evaluation for Chinese improved 1000 MWe PWR. Ann Nucl Energy 2015;76:343–9.
- [19] Magallon D, Huhtiniemi I, Hohmann H. Lessons learnt from FARO/TERMOS corium melt quenching experiments. Nucl Eng Des 1999;189(1–3):223–38.
- [20] Magallon D, Huhtiniemi I. Corium melt quenching tests at low pressure and subcooled water in FARO. Nucl Eng Des 2001;204(1–3):369–76.
- [21] Karbojian A, Ma WM, Kudinov P, Dinh TN. A scoping study of debris bed formation in the DEFOR test facility. Nucl Eng Des 2009;239(9):1653–9.
- [22] Ma WM, Dinh TN. The effects of debris bed's prototypical characteristics on corium coolability in a LWR severe accident. Nucl Eng Des 2010;240(3):598–608.
- [23] Kymäläinen O, Tuomisto H, Hongisto O, Theofanous TG. Heat flux distribution from a volumetrically heated pool with high Rayleigh number. Nucl Eng Des 1994;149(1–3):401–8.
- [24] Theofanous TG, Maguire M, Angelini S, Salmassi T. The first results from the ACOPO experiment. Nucl Eng Des 1997;169(1–3):49–57.
- [25] Sehgal BR, Bui VA, Dinh TN, Green JA, Kolb G. SIMECO experiments on in-vessel melt pool formation and heat transfer with and without a metallic layer. In: Proceedings of the Workshop on In-Vessel Core Debris Retention and Coolability; 1998 Mar 3–6; Garching, Germany; 1998. p. 198–206.
- [26] Gaus-Liu X, Miassoedov A, Cron T, Wenz T. In-vessel melt pool coolability test—description and results of LIVE experiments. Nucl Eng Des 2010;240(11):3898–903.
- [27] Asmolov V, Tsurikov D. RASPLAV project: major activities and results. In: Proceedings of OECD/NEA RASPLAV Seminar; 2000 Nov 14–15; Munich, Germany; 2000.
- [28] Bonnet JM. Thermal hydraulic phenomena in corium pools for ex-vessel situations: the BALL experiment. In: Proceedings of the 8th International Conference on Nuclear Engineering; 2000 Apr 2–6; Baltimore, Maryland. New York: American Society of Mechanical Engineers; 2000. p. 79–86.
- [29] Zhang LT, Zhang YP, Zhao B, Ma WM, Zhou YK, Su GH, et al. COPRA: a large scale experiment on natural convection heat transfer in corium pools with internal heating. Prog Nucl Energy 2016;86:132–40.